

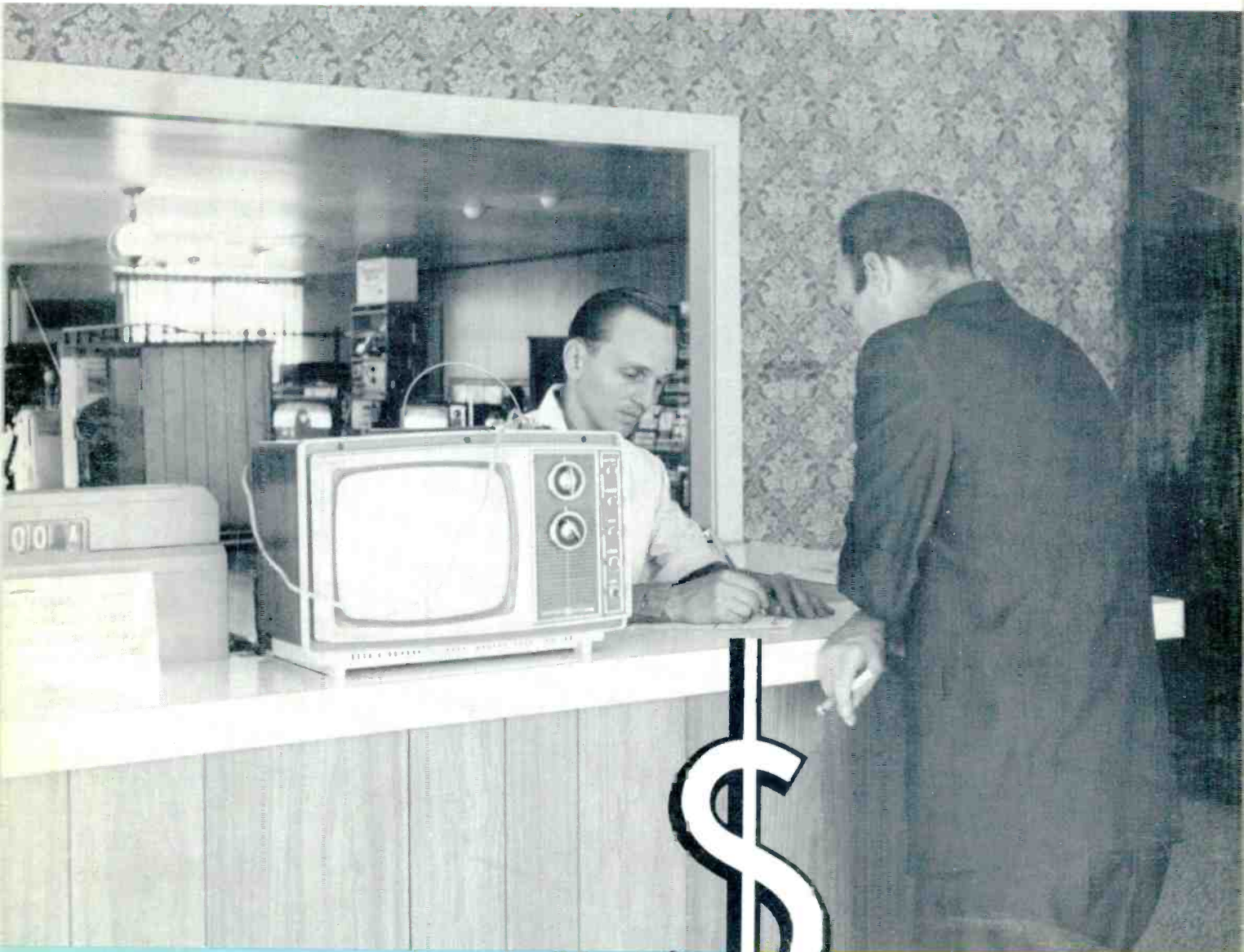

Electronic Servicing



Noise in TV sound,
page 32

How bandwidth affects
picture quality,
page 26

Pricing
Service Labor
Profitably and
Competitively,
page 10

NOW you can measure resistors accurately **IN CIRCUIT!**

in solid state devices



FE20 HI-LO
with hi-voltage probe and large
six-inch meter **\$129.50**



FE21 HI-LO
with 4 1/2-inch
meter **\$99.50**

WITH THE NEW HI-LO FIELD EFFECT MULTIMETERS

USES ONLY .08 VOLTS TO POWER OHMMETER TO PREVENT TRANSISTORS FROM CONDUCTING AND UPSETTING READINGS

Look at these extra features to see why the Hi-Lo meter belongs on your want list:

- Unbelievable specifications of 15 megohm input impedance on DC and 12 megohms on AC
- Laboratory accuracy of 1.5 percent on DC and 3 percent on AC
- 9 DC voltage ranges from as low as .1 volts full scale to 1000 volts
- 3 hi-voltage ranges of 3 KV, 10 KV and 30 KV
- 9 DC zero center ranges from .05 volts to 500 volts . . . a must for delicate transistor bias measurements
- 7 resistance ranges from 1000 ohms full scale to 1000 megohms
- 9 DC current ranges from 100 microamps to 1 amp
- Automatic built-in battery test . . . never a worry about rundown batteries, just push the switches under the meter and read.
- Standard .6 amp fuse to protect the ohms and milliamps scales if voltage or overload is accidentally applied. No more need to return the meter to factory for repair . . . just replace the fuse.
- Special probe with 100K isolation resistor in probe to prevent AC pickup or to prevent loading oscillator circuits. Leave in normal position for most tests.

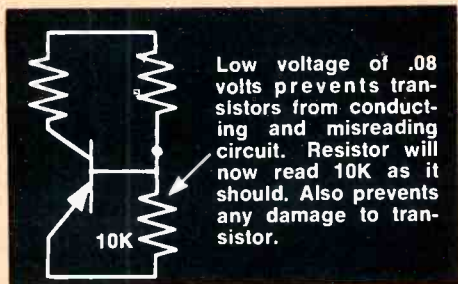

Here is why you should have both Hi and Lo battery voltages for correct in-circuit resistance measurements in solid state circuits:

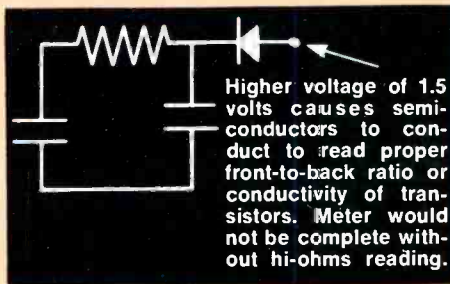

SENCORE INC. 3200 Sencore Drive • Sioux Falls, South Dakota 57107

Circle 1 on literature card

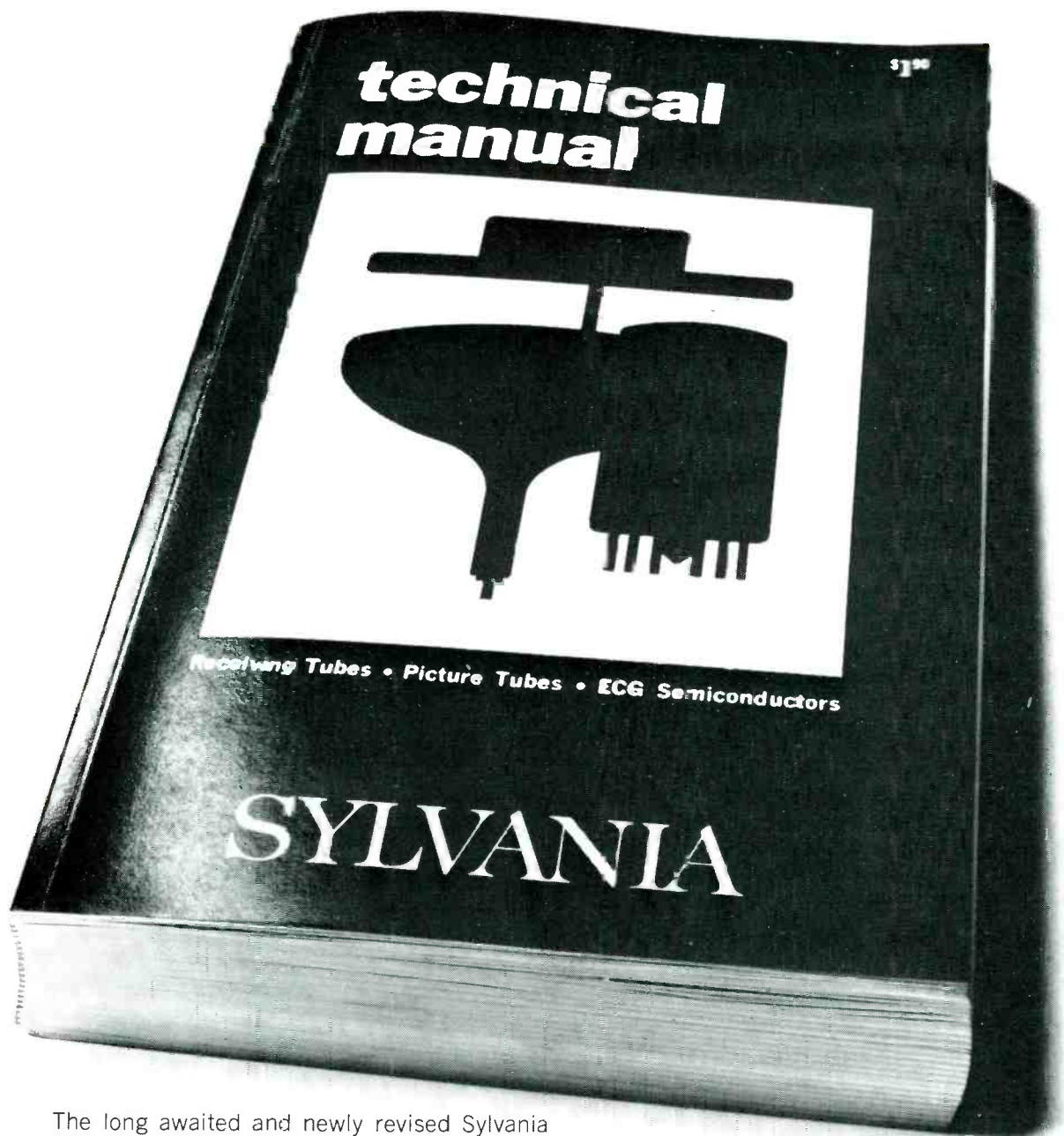

The long awaited and newly revised Sylvania Technical Manual is out. Complete and unexpurgated. The fantasy of every Independent Service Technician. Written anonymously by an agile team of Sylvania engineers. 32,000 components described in breathtaking detail. Including thousands of unretouched diagrams and illustrations. Discover the unspeakable thrill of new color TV Tubes, listed as never before. The ecstasy of 28,000 ECG Semiconductors.

From exotic Deflection Oscillators to a lurid account of Transistors and Rectifiers.

This book has what you want. Components for the man who knows what to do with them.

The 14th Edition of the Sylvania Technical Manual is not available in any bookstore. Your Sylvania Distributor is discreet. Speak to him.

SYLVANIA
GENERAL TELEPHONE & ELECTRONICS

Circle 3 on literature card

“Electrifying”

August, 1970/ELECTRONIC SERVICING 1

Electronic Servicing

Formerly PF Reporter

in this issue...

- 10 Pricing Service Labor Profitably and Competitively.** Your hourly service labor charge should be based on what it actually costs **you** to produce one hour of service labor, not what it costs the shop down the street or one two thousand miles away. This article outlines a simple procedure for determining the minimum hourly service labor rate **you** must charge to realize the profit **you** desire from **your** shop. **by J. W. Phipps.**
- 16 Stereo Trouble—Tuner or Amplifier.** The trend to fewer separate units in stereo systems makes localization of the trouble source more difficult, particularly when the trouble symptom could be caused by two or more units of the system. The procedures, tips and analysis of common troubles provided in this article will speed up your servicing of such sets. Also examined are problems caused by mismatch of units in component-type systems. **by Leonard Feldman.**
- 26 How Video IF and Chroma Bandwidth Affect Picture Quality.** Ringing, fuzziness, unstable sync, poor color "fit" and other trouble symptoms that reduce the quality of the displayed picture commonly are caused by defects that affect the frequency and phase characteristics of the video IF and chroma amplifiers. This article examines these defects and explains how to isolate them. **by Robert G. Middleton.**
- 32 Sources of Noise in TV Sound.** Proven techniques for quickly locating and curing the common causes of buzz and other spurious noises that often plague television receivers. **by Wayne Lemons.**
- 40 Mobile Radio Servicing, Part 3.** The final installment of this three-part series outlines the step-by-step procedures for accomplishing proof-of-performance tests required by the FCC. **by Leo G. Sands.**
- 52 RCA's Motorless TV Remote Control System.** How the on/off function and adjustment of volume, tint and color saturation of this manufacturer's CTC47 color chassis are controlled remotely without the use of motors, plus related troubleshooting tips. **by Bruce Anderson.**

DEPARTMENTS

Letters to the Editor	4	Troubleshooter	38
Electronic Scanner	7	Antenna Systems Report . .	50
Symcure	14	Product Report	58
Test Equipment Report . .	24	Catalog and Literature . . .	62
Book Review	31	Advertisers' Index	64

Second class postage paid at Kansas City, Mo. and additional mailing offices. Published monthly by INTERTEC PUBLISHING CORP., 1014 Wyandotte St., Kansas City, Mo. 64105. Vol. 20, No. 8. Subscription rates \$5 per year in U.S., its possessions and Canada; other countries \$6 per year.

Copyright, 1970, Howard W. Sams & Co., Inc. All rights Reserved. Material may not be reproduced or photocopied in any form without written permission of publisher.

EDITORIAL
 GEO. H. SEFEROVICH, Director
 J. W. PHIPPS, Managing Editor
 CARL BABCOKE, Technical Editor
 MARY M. SYMON, Editorial Assistant
 DUDLEY ROSE, Art Director

CONTRIBUTING AUTHORS
 Bruce Anderson
 Allan Dale
 Robert G. Middleton

TECHNICAL CONSULTANT
 JOE A. GROVES

EDITORIAL ADVISORY BOARD
 LES NELSON, Chairman
 Howard W. Sams & Co., Indianapolis

CIRCULATION
 ROBERT M. CURRY, Director
 EVELYN ROGERS, Manager

ADVERTISING SALES
 Kansas City, Missouri 64105
 Tele: 913/888-4664
 E. P. LANGAN, Director
 R. JACK HANCOCK, Manager
 JAKE STOCKWELL
 S. F. WILSON, Production

REGIONAL ADVERTISING SALES OFFICES
Indianapolis, Indiana 46280
 ROY HENRY
 2469 E. 98th St.
 Tele: 317/846-7026

New York, New York 10019
 CHARLES C. HORNER
 3 W. 57th St.
 Tele: 212/688-6350

Los Angeles, California 90005
 JOHN D. GILLIES
 3600 Wilshire Blvd., Suite 1510
 Tele: 213/383-1552

London W. C. 2, England
 JOHN ASHCRAFT & CO.
 12 Bear Street
 Leicester Square
 Tele: 930-0525

Amsterdam C. Holland
 JOHN ASHCRAFT & CO.
 W.J.M. Sanders, Mgr.
 for Benelux & Germany
 Herengracht 365
 Tele: 020-240908

Tokyo, Japan
 INTERNATIONAL MEDIA
 REPRESENTATIVES LTD.
 1, Shiba-Kotohiracho, Minatoku
 Tele: 502-0656



ELECTRONIC SERVICING (with which is combined PF Reporter) is published monthly by Intertec Publishing Corp., 1014 Wyandotte Street, Kansas City, Missouri 64105.

Subscription Prices: 1 year—\$5.00, 2 years—\$8.00, 3 years—\$10.00, in the U. S. A., its possessions and Canada.

All other foreign countries: 1 year—\$6.00, 2 years—\$10.00, 3 years—\$13.00. Single copy 75¢; back copies \$1.



Robert E. Hertel, Publisher
 Intertec Publishing Corp.
 Subsidiary of Howard W. Sams & Co., Inc.

Do you judge capacitors
on the same basis
Bill Dickerson does?

Then you'll use
Sprague Twist-Lok[®] Capacitors when
you need twist-prong electrolytics.



To be successful, a TV service dealer has to be fussy about a lot of things. No one knows it better than Bill Dickerson of Central Radio and Television, Santa Barbara, California. He's building on his 17 years' servicing experience every day in a spot where being fussy counts a lot. Central Radio is 14 people strong and has 4 service trucks on the go. It's easy to see why Bill prefers Sprague Twist-Lok Capacitors. They can be used as exact replacements to avoid call-backs. It pays to be fussy.

Ask your Sprague distributor for a copy of Sprague's Electrolytic Capacitor Replacement Manual K-109 or write to: Sprague Products Company, 105 Marshall St., North Adams, Mass. 01247.

P.S. You can increase your business 7½% by participating in EIA's "What else needs fixing?" program. Ask your distributor or write to us for details.

Circle 4 on literature card



Realistic Prices Too High?

Three cheers for Mr. Irvan and his idea (*Letters to the Editor*, April, '70) titled "Shop Owners and Technicians Under Customer's Thumb."

The only problem I see is that when we "turn on the lights and start charging realistic prices" we will price ourselves right out of business. We not only are competing with each other but also with the manufacturer, who is turning out a continually cheaper (and poorer) product. We no longer can afford to service most radios, because a new one costs so little.

In a few years we will be in the same position as the noble horse, who was of great service for many years, but now is allowed to live only as a plaything.

With the coming of the miniature plug-in panels, there will be no need for technicians of a high caliber or in the large numbers needed today. While present sets using this technique are rather comical, if engineered properly it would be possible for a person with a sixth grade education (or even a customer?) to service television and do a good job.

In the same edition of *ELECTRONIC SERVICING* there is an article on incentive pay for technicians. There is only one thing wrong with the idea. We are already working at full speed. As the old saying goes, "The hurrier I go the behinder I get."

The article does not cover to any extent how call-backs are due to poor reception conditions or inability of the customer to operate his set. Under the incentive pay plan it would be most difficult for a technician to remain pleasant and spend the time with the customer, explaining the facts of reception or proper operation of television to the customer's satisfaction. After all, satisfying the customer is what this (or any other) business is all about. I concede this is an almost impossible job in the electronic servicing business.

Mervin Collier
Campbellsburg, Ind.

Mr. Collier, an article in this issue of *ELECTRONIC SERVICING* examines in-depth all the aspects of profitable and realistic pricing. However, there is one point I would like to make here: Although satisfying the customer is a necessary function of this and any business, it should not be "what this business is all about." The first consideration should be that the business produce a reasonable profit. Unless this consideration is satisfied, it won't matter how well you treat the customer because you either will be out of business or operating without receiving compensation for your time and investment.

Many Thanks

In the April '70 issue of *ELECTRONIC SERVICING*, you ran my request for assistance in finding a 12AE7 tube.

I have been swamped with letters, cards and tubes from all over the country. It is physically impossible for me to answer all this mail, yet I would still like to thank all these nice people. I could think of no other way except to turn back to this magazine for help.

A million thanks to all the people who answered my SOS for a 12AE7 tube. The mail was overwhelming. Please accept this note as my appreciation.

Tony Kobel
R.R. #2, Box 344
Groveland, Fla. 32736

PHOTOFACT Folders For Sale

I am going out of the repair business after 12 years and am selling my Sams PHOTOFACT folders. I have No. 34 through 1019, which I will sell as a set only, complete with file cabinets.

Kenneth R. Kolthoff
140 Iowa
Jacksonville, Ark. 72076
(501) 988-4709

Help Needed

We need a schematic and instruction manual for a Sonora electronic organ, Model 200 400. The company that built this organ, Sonora Electronics, Inc., Chicago, Ill., has been out of business many years.

Any help will be greatly appreciated.

Norman L. Fitkin
207 Circle
Sebring, Fla. 33870

I am in urgent need of the meter used in the Superior ohmmeter Model TV 60. I have been unable to locate the Superior Instrument Co. by mail. I will gladly pay any cost for this information or any help.

Franklin Estremeras
Bda. Dr. Pila
Ploque #21, Apt. 339
Ponce, Puerto Rico 00731

I need a meter for a Super-Meter Model 670-A put out by Superior Instruments Co., New York, New York. Thank you for any help.

Arthur F. Crow
Route 2, Box 157
DeRidder, La. 70634

I purchased a capacitor analyzer, Model CT-400, manufactured by Oxford-Tartak Radio Corp., which I assume is out of business.

I would like to get an operating manual and schematic for this unit. Can someone help me? I would appreciate any assistance.

Gamaliel Gamez
832 E. Camille
Santa Ana, Calif. 92701

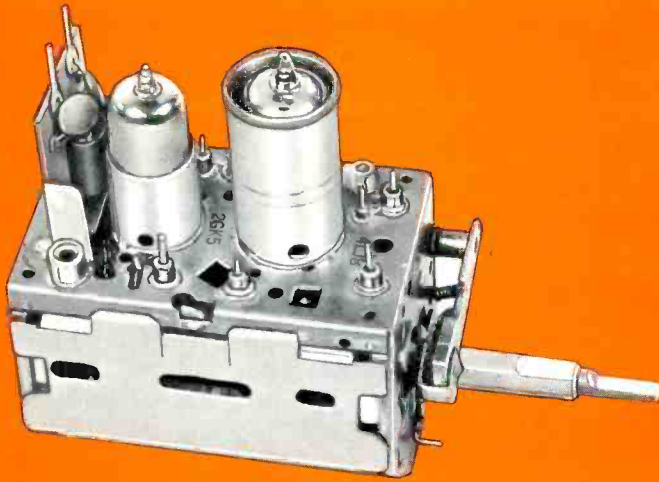

\$975

TUNER SERVICE CORPORATION

PROVIDES YOU WITH A COMPLETE SERVICE FOR ALL YOUR TELEVISION TUNER REQUIREMENTS AT ONE PRICE.

TUNER REPAIR

VHF Or UHF Any Type \$9.75.
UHF/VHF Combo \$15.00.

In this price all parts are included. Tubes, transistors, diodes, and nuvistors are charged at cost.

Fast efficient service at our 4 conveniently located service centers.

1 year guarantee backed up by the largest tuner manufacturer in the U.S.—SARKES TARZIAN INC.

All tuners are cleaned inside and out, repaired, realigned and air tested.

TUNER REPLACEMENT

Replacement Tuner \$9.75.

This price buys you a complete new tuner built specifically by SARKES TARZIAN INC. for this purpose.

The price is the same for every type of universal replacement tuner.

Specify heater type

Parallel 6.3V
Series 450 mA
Series 600 mA

All shafts have the same length of 12".

Characteristics are:

Memory Fine Tuning
UHF Plug In
Universal Mounting
Hi-Gain Lo-Noise

If you prefer we'll customize this tuner for you. The price will be \$18.25. Send in original tuner for comparison purposes to our office in INDIANAPOLIS, INDIANA.



TUNER SERVICE CORPORATION

FACTORY-SUPERVISED TUNER SERVICE

MIDWEST 817 N. PENNSYLVANIA ST., Indianapolis, Indiana TEL: 317-632-3493
(Home Office)
EAST 547-49 TONNELE AVE., Jersey City, New Jersey TEL: 201-792-3730
SOUTH-EAST 938 GORDON ST., S. W., Atlanta, Georgia TEL: 404-758-2232
WEST SARKES TARZIAN, Inc. TUNER SERVICE DIVISION
10654 MAGNOLIA BLVD., North Hollywood, California TEL: 213-769-2720

Circle 5 on literature card

I am searching for a rather unique piece of electronic gear and am not having much success.

I am looking for a tuner that will give me the audio of the VHF television band. I know that there is one on the market—a portable radio that will give me just that—but I want a unit with far better fidelity than that unit can supply. I want to be able to tape the audio portion of some of the musical specials that are presented, and would like them in high-fidelity sound, which the portable does not give.

I know that an item identical to that which I desire was made several years ago, but I do not know the name of the company.

Can any of your readers help me? I would rather have a new piece of equipment, but will settle for a used one as long as it is in good working condition.

Melvyn E. Shlank
1326 Whalley Avenue
New Haven, Conn. 06515

I will pay reasonable prices for back issues of Electronic Technician/Dealer magazine, years 1967, 1968 and 1969. I also need the April and May '69 issues of ELECTRONIC SERVICING magazine.

R. Stanley
4624 N. Marvine Street
Philadelphia, Pa. 19140

I have an old Victrola which is about 50 years old. It is a hand-wound type, but the spring is broken. I

would like to know where I can obtain another spring, or the address of the manufacturer if they are still in business. It is a "Brunswick" Model 210-452561, made by the Brunswick-Balke Collender Company. Thank you.

Gerald B. Landry
34 Pineland Street
Lewiston, Maine 04240

I have a Jackson Model 600 oscilloscope which has a bad 5-BTPI CRT. I have been unable to find a replacement for this tube, which is 12 inches long.

I was wondering if a 5UPI could be modified to work in this model, or, if anyone knows, where I can purchase a 5-BTPI.

Thank you.

Martin J. Walsh
649 Crawford
Toledo, Ohio 43612

I am in need of a schematic diagram for a "DOSS" Pioneer 250 Horizontal Sweep Quantalyst, built by Doss Electronic Research, Inc., who are no longer in business. Maybe one of your readers could furnish me with a diagram so that I could wire in new adapters for color TV servicing.

Maurice Dubreuil
1740 Notre-Dame
Lavaltrie, Quebec, Canada ▲

Your caddy is the only caddy our tubes fit.

Because we market our tubes only through you—the independent serviceman.

We don't have service trucks or retail outlets. Our tube caddies are available only to you.

You see, we're independent too—the largest independent tube supplier in the business. We have to cooperate with you—not compete. Because we depend on you just as you depend on us.

RAYTHEON

Circle 6 on literature card

Free Warranty Service Labor Is Now Rule Instead of Exception

Inclusion of free service labor during the warranty period is now included in the 1971 warranty programs of most major manufacturers of TV. Most manufacturers offer free warranty service labor for 90 days, although two manufacturers, RCA and Motorola, offer 1-year coverage.

Emerson and General Electric are the only major full-line manufacturers who, to date, do not have official company labor-warranty policies on color receivers, although some of their sets are backed by distributor warranty labor policies.

ADMIRAL

Admiral has adopted, as official company policy,

the 90-day labor warranties that many of its independent and factory branch distributors have been offering. The "Mastercare" program provides warranty service labor coverage for either in-home or carry-in service, depending on type of set. Admiral is continuing its three-year replacement warranty on color CRT's.

MOTOROLA

Motorola is offering one year of free warranty labor on its new 16-inch and 25-inch Quasar color TV receivers—"carry-in" for the 16-inch portables and "in-home" for the 25-inch models.

One-year free service labor is not included in the warranties of previously introduced Quasar and Quasar II color models, although they and the new 16-inch and 25-inch color receivers will be covered by the

RCA Holds Lead in Color; Zenith Out in Front in B-W

The gap between the No. 1 and No. 2 positions in both color and b-w TV sales has narrowed to just 3 percentage points, according to **TV Digest's** annual share-of-market survey, the results of which were published recently in **TV Digest**.

Although **TV Digest** cautions that the survey isn't intended to be anything but a "well-educated collective industry guesstimate", it might be the most accurate indication of TV marketing trends available.

Shown here is a condensed version of the computed results of the survey.

SHARE OF DOMESTIC-LABEL MARKET

Color TV

1970 Model Year			1969 Model Year		1968 Model Year	
Rank	Brand Name or Company	% of Mkt. (median)	Rank	% of Mkt. (median)	Rank	% of Mkt. (median)
1	RCA	25.0	1	27.5	1	30.0
2	Zenith	22.0	2	21.0	2	20.0
3	Magnavox	11.0	3	10.0	3	9.0
4	Sears	7.75	4	7.0	6	6.0
5	Motorola	6.25	5	6.0	4	7.0
6	Admiral	5.5	6*	5.5	5	6.5
7	GE	5.0	6*	5.5	7	5.25
8	Sylvania	5.0
..	Philco-Ford	8	4.0
Total, ranked brands		87.5	..	82.5	..	87.75
All others		12.5	..	17.5	..	12.25

*Admiral & GE tied for 6th place in 1969 model year.

Monochrome TV

1	Zenith	21.0	1	22.0	1	22.0
2	RCA	18.0	2	17.0	2	17.0
3	GE	11.0	3	12.5	3	11.0
4	Sears	9.75	4	9.5	4	8.25
5	Admiral	7.5	5	7.0	5	8.0
6	Motorola	6.0	6	6.0	6	6.5
7	Magnavox	6.0	8	5.25	8	4.5
8	Philco-Ford	5.0	7	6.0	7	6.0
Total, 8 brands		84.75	..	85.25	..	83.25
All others		15.75	..	14.75	..	16.75

Tron Rectifier Fuses



Available in sizes from 1/2 to 1000 amps for voltages up to 1500, TRON Rectifier Fuses are ideal for protecting variable speed drives, inverters, battery chargers, plating power supplies, power controls, and any other application where fast opening and great current limitation are required.

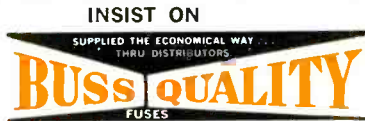

Write for BUSS Form TRFS

Bussmann Mfg. Division, McGraw-Edison Co., St. Louis, Mo. 63107

for servicing the antenna system, travel time and mileage and extra charges for service performed after normal shop hours.

ZENITH

This manufacturer's "Consumer Protection Plan" includes 90-day free service labor for all of its 1971 color TV receivers.

The labor coverage is for in-home service of consoles and large-screen table models (20-inch and larger), and carry-in service of portable and compact table models (14- through and including 19-inch sets).

Zenith also stipulates that, to qualify for free service labor during the first 90-day period of the warranty, the service must be performed by the local Zenith dealer from whom the set was purchased, or by his independent servicing contractor.

The Zenith "Consumer Protection Plan" was made possible, in part, "by the experience of independent servicing dealers throughout the country whose recommendations are often reflected in Zenith engineering design and service policies," according to W. C. Fisher, president of the Zenith Sales Company.

Zenith will continue to offer one-year warranty of parts and two-years warranty of color picture tubes.

More Solid-State Components, 25-Inch Screens and Pre-Programmed Electronic Tuning in '71 TV Lines

Increased use of solid-state components and all-

BUSS: The Complete Line of Fuses and . . .

continuing two-year parts guarantee.

The new one-year service labor warranty stipulates that the servicing must be accomplished by a Motorola authorized servicer.

To establish a line of authorized Motorola servicers eligible to accomplish servicing under the in-boarded labor warranty, Motorola reportedly is mailing a "professional services profile and rate structure" questionnaire to more than 5000 servicers of Motorola products, requesting such information as:

- Type of test equipment servicer has
- Number of technicians employed
- Average prices he would require to perform carry-in and in-home servicing under the new warranty program.

The completed questionnaires are to be mailed to the Motorola local distributor, who will review it and decide which servicers in his area qualify. Billing and reimbursement for warranty servicing will be handled by the local distributor.

The new labor guarantee reportedly does not cover labor charges incurred for: a) delivery; b) installation and/or initial setup; c) customer instruction; d) correction of malfunctions caused by customer misuse, abuse or misadjustment; or e) correction of problems that are not related to either 1) defects in materials or 2) faulty workmanship.

The labor guarantee also does not cover charges

FUSES

for protection of Electronic Devices



There is a complete line of BUSS Quality fuses in 1/4 x 1 inch, 1/4 x 1 1/4 inch, and miniature sizes, with standard and pigtail types available in quick-acting or dual-element slow blowing varieties.



Write for BUSS Form SFB

Bussmann Mfg. Division, McGraw-Edison Co., St. Louis, Mo. 63107

Circle 7 on literature card

FUSEHOLDERS

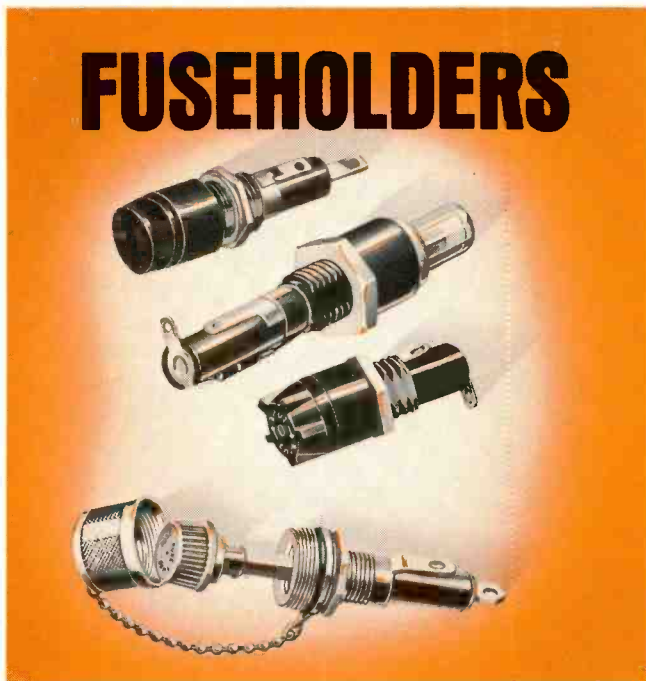

BUSS has a complete line of fuseholders to cover every application. It includes lamp indicating and alarm activating types, space-saving panel mounted types, in-line holders, RFI-shielded types, and a full line of military types. Most are available with quick-connect terminals.

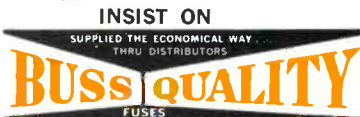

Write for BUSS Form SFB

Bussmann Mfg. Division, McGraw-Edison Co., St. Louis, Mo. 63107

some models of the new line, including the two top-of-the-line, 25-inch color receivers. An electro-mechanical detent UHF tuner, similar to present VHF tuners, is used in three of the other 25-inch color console models.

Philco's Cosmetic Color circuit, which maintains proper flesh tones independent of broadcast signal changes, is used on all color receivers having screens 16 inches and larger.

SYLVANIA

Electronic push-button channel selection and simultaneous tuning of all channels 2-83 is available on the ten 25-inch color consoles, which also employ all-solid-state chassis. The same thing also is available on Sylvania's two "home entertainment centers".

All color receivers employ Sylvania's new solid-state, high-voltage multiplier.

List of 25-Inch Color Marketers Grows

Admiral, Magnavox, Philco and Sylvania have added their names to the list of color TV manufacturers who have included 25-inch color TV screens in their 1971 lines.

The new 25-inch color CRT will provide about 20 square inches more of viewing area than do existing 23-inch picture tubes. Total viewing areas for the two large CRT's are 295 square inches for 23-inch CRT's and about 315 square inches for the new 25-inch screens. ▲

Fuseholders of Unquestioned High Quality

electronic tuners are highlighted in the 1971 TV lines introduced to date.

ADMIRAL

Eighteen out of 31 models in the 12-, 16-, 23- and 25-inch receivers have solid-state devices in 80 percent of the circuits.

An integrated circuit containing the complete sound section—sound IF amplifier, detector and audio amplifier—is used in the K-20 color chassis.

A circuit for maintaining proper flesh tones regardless of changes in the broadcast signal (including switching channels) is incorporated in all 25-inch color receivers.

MOTOROLA

An electronic all-channel VHF/UHF tuner will be employed in some of the top-of-the-line Quasar model color receivers. The tuner reportedly is designed for automatic programming of a combination of up to 13 VHF and UHF channels.

Modular design, employing six plug-in boards, is used in various models with screen sizes ranging from 16-inch to 25-inch.

Integrated circuits are used in the color demodulator and sound system of various models, including the two 16-inch portable color receivers.

PHILCO

A UHF electronic tuner that permits pre-selection and fine tuning of up to 6 UHF channels appears in

FUSEBLOCKS

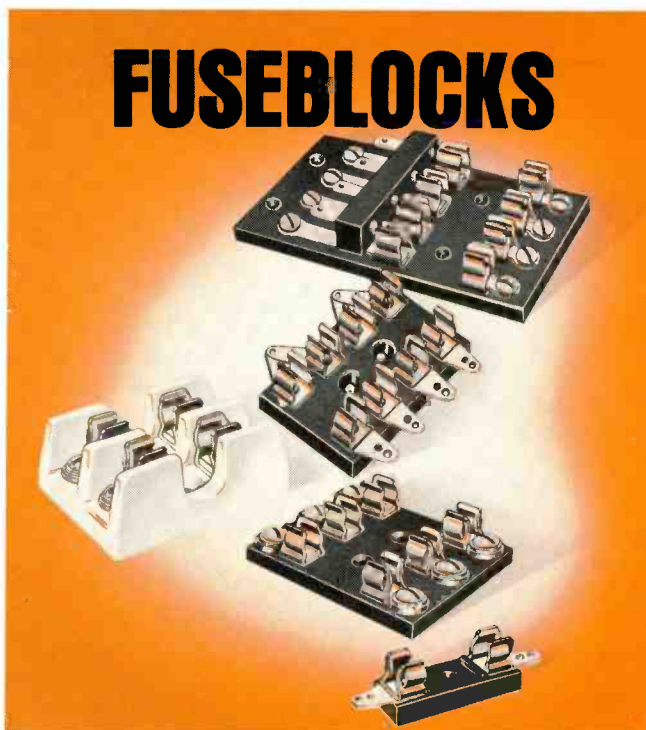

There is a full line of BUSS Quality fuseblocks in bakelite, phenolic, and porcelain, with solder, screw-type, or quick-connect terminals.



Write for BUSS Form SFB

Bussmann Mfg. Division, McGraw-Edison Co., St. Louis, Mo. 63107

Circle 8 on literature card

Pricing service competitively and profitably

Your hourly service charge should reflect **your** costs, the labor recovery rate of **your** shop and the profit **you** desire.

Fig. 1—Method for Computing Hourly Service Labor Charge

1) Technician Wages and related payroll expenses	+	Shop Operating Expenses	+	General and Administrative Expenses	=	Total Cost to Produce Service Labor
2) Total Cost To Produce Service Labor	+	Desired Profit	=			Total Service Labor Revenue Required
3) Manhours available during period	×	% of labor recovered for direct sale to customers	=			Manhours available for direct sale
4) Total Service Labor Revenue Required	÷	Manhours available for sale	=			MINIMUM HOURLY RATE REQUIRED TO PRODUCE DESIRED PROFIT

Fig. 2—STEP 1A—Computing Service Labor Costs for Ohm's TV and Radio

WAGES	Bob	Joe	Sam	TOTAL
Technician Hours per year	2496	2496	2496	
Multiply by hourly wage	× \$4.00	× \$3.50	× \$3.00	
Annual wages	\$9984	\$8736	\$7488	\$26,208
OTHER PAYROLL COSTS				
Social Security Life & Medical Insurance	\$317	\$317	\$317	
Unemployment	120	120	120	
	299	262	224	
	\$736	\$699	\$661	\$2,096
Total Service Labor Costs				\$28,304

Profitable and competitive pricing of service labor involves three primary functions:

- Accurate accounting of what it costs **you** to produce service labor.
- Computing of cost data to arrive at the minimum service labor charge which will enable you to realize the profit you desire.
- Periodic review of costs, shop efficiency, competitors service labor rates, and other factors that could require adjustment of your hourly service labor charge.

How To Compute Your Minimum Hourly Service Labor Charge

Step-by-Step Procedure—Profitable pricing of service labor involves a procedure so simple in concept it can be summarized as follows:

- 1) Compute **all** expenses (labor, operating and administrative) incurred in the operation of **your** business during a specific period (1 month or 1 year)
- 2) Add to total expenses the profit you desire. The sum thus produced is the minimum receipts (revenue) you must realize from sale of service labor for the specified operating period.
- 3) Determine what percentage of the total manhours available during the period can actually be charged directly to customers (labor recovery rate). Paid vacation time, paid sick leave time, etc., cannot be charged **directly** to customers; your cost for these must be recovered indirectly.
- 4) Divide the figure arrived at in Step 2 (service labor receipts) by the figure arrived at in Step 3 (manhours available for direct sale). The result will be the minimum price you must charge for 1 hour of service labor, if you are to realize the profit you desire.

An even briefer outline of this step-by-step procedure is shown in Fig. 1.

**A Practical Example of How
The Profitable Hourly Charge
for Service Labor Can
Be Computed**

Ohm's TV and Radio Service (fictitious), owned and operated by John Ohm, employs three technicians and is open for business 8 hours a day, 6 days a week.

In the following paragraphs we will compute for John Ohm the hourly service labor charge he must receive to realize the profit he desires.

STEP 1—Determining Total Cost To Produce Service Labor Cost of Service Labor—Service labor costs for Ohm's TV and Radio are shown in Fig. 2. John himself no longer does servicing, except when one of his three technicians runs into a difficult diagnostic problem; most of his time is devoted to management of the business. Consequently, the annual salary he pays himself is included in "shop operating expenses" instead of "service labor cost".

Shop Operating, General and Administrative Expenses—Fig. 3 shows all the other business expenses paid out by John Ohm during the year. Note that depreciation of vehicles and shop equipment (test equipment, work benches, carts, etc.) are included in "Operating Expenses", and depreciation of office equipment is included in "General and Administrative Expenses". Such expenses must be recovered because the items involved eventually will have to be replaced, either because they wear out and become uneconomical to repair, or because changing designs and new technology make them obsolete. If the depreciation is not pro-rated over the useful life of the item and recovered during this period, when replacement is required no reserve funds will be available with which to purchase the necessary new equipment, and the shop owner either will have to purchase such items out of his operating capital, if he has sufficient capital, or he will have to borrow the money, (with additional expense for interest). Either way, the money comes out of the profit he earned previously or will earn in the future.

Total Expenses—As indicated in

Fig 3—STEP 1B—Computing Total Operating, General and Administrative Expenses for Ohm's TV and Radio

OPERATING EXPENSES		
Owner's salary (including all payroll costs)	\$13,114	
Vehicle operating and maintenance	1,400	
Vehicle depreciation	1,600	
Shop equipment depreciation	900	
Expendable items, shop	350	
Service literature	75	
	<hr/>	\$17,439
GENERAL AND ADMINISTRATIVE EXPENSES		
Secretary wages	5,200	
Lease	3,600	
Utilities	1,000	
Telephone	550	
Office equipment depreciation	100	
Office supplies	450	
Advertising/Promotion	600	
Legal/Audit fees	300	
Insurance (all other than employee)	250	
Taxes (other than Fed. and State income)	600	
Interest and Bank Charges	500	
Dues, subscriptions, license fees, etc.	250	
Misc. (bad debts, etc.)	250	
	<hr/>	13,450
Total Operating, General and Administrative Expenses		<hr/> \$30,889

Fig. 4—STEP 1C—Computing Total Cost of Producing Service Labor—Ohm's Radio & TV

Service Labor (Fig. 2)	\$28,304
Operating, General and Administrative (Fig. 3)	30,889
	<hr/>
Total	\$59,193

Fig. 5—STEP 2—Computing Total Annual Service Labor Revenue Required to Produce Desired Profit For Ohm's TV and Radio

Total Cost of Producing Labor (Fig. 4)	\$59,193
Profit Desired (20% of Labor Sales before Taxes)	× .20
	<hr/>
	\$11,838
Total Expenses	\$59,193
Desired Profit	+ 11,838
	<hr/>
Service Labor Revenue Required	\$71,031

Fig. 6—STEP 3—Labor Recovery Rate: Computing Service Labor Manhours That Actually Will Be Available For Direct Sale

Hours worked per year per technician	2496
Number of technicians	× 3
	7488
Shop service labor manhours per year	7488
Minus manhours lost to vacations (2 weeks per technician)	— 288
	7200
Manhours on job	7200
Labor recovery rate (80%)	× .80
	5760
Total service labor manhours available for direct sale	5760

Fig. 7—STEP 4—Computing Minimum Hourly Rate Required to Produce Desired Profit

Total Service Labor Revenue Required (Fig. 4)	=	\$71,031	=	\$12.33 Minimum Hourly Service Labor Charge
Service Labor Manhours Available for Direct Sale (Fig. 6)		5760 hours		

Fig. 8—Minimum Hourly Service Labor Charge Varies With Labor Recovery Rate *

Labor Recovery Rate (%)	Minimum Hourly Service Labor Charge
70	\$14.09
80	12.33
85	11.61
90	10.96

*To determine labor recovery rate, divide last year's total annual receipts by the hourly service labor rate charged; then divide the resultant figure by the manhours actually available for sale:

Total Annual Receipts	=	Manhours Actually Sold
Hourly Service Labor Charge		
Manhours Actually Sold	=	Labor Recovery Rate (%)
Manhours Available for Sale		

Fig. 4, expenses incurred by Ohm's TV and Radio in the production of service labor totaled \$59,193.

STEP 2—Determining Total Service Labor Revenue Required to Obtain Desired Profit

There are two common methods for computing and comparing desired annual profit:

One involves "return on investment", which is computed by multiplying the total capital invested in the business by the then reasonable percentage rate for high-risk investments.

However, because John Ohm's total investment is relatively small, and using it to compute a profit would not produce a reasonable amount, John uses the other common method: "percentage of total

labor sales receipts, before taxes."

John has analyzed the profits realized from other types of businesses similar to his and has decided that 20 percent of labor sales before taxes is an acceptable rate of profit for his business. (Radio and TV service shops in 1969 realized an average profit of 12.98 percent, according to statistics gathered and published by the Accounting Corporation of America.) Fig. 5 shows the actual computations, which reveals that, to realize the desired 20 percent profit, Ohm's TV and Radio must receive at least \$71,031 in service labor receipts during the 12-month period.

STEP 3—Computing Amount of Service Labor Manhours That Will Produce Revenue
John Ohm employs three full-time

technicians; each technician works 48 hours per week, 50 weeks per year (each receives two weeks paid vacation per year). As shown in Fig. 6, John Ohm pays for 7488 service labor manhours per year, of which 288 are lost to paid vacations. A portion of the remaining 7200 manhours will be lost because of employee sickness, coffee breaks and other nonproductive activities that cannot be charged directly to customers' bills. Records from the previous year show John that he reasonably can expect to recover for direct sale to customers about 80 percent of these 7200 manhours.

STEP 4—Computing Minimum Hourly Rate Required to Produce Desired Profit

Shown in Fig. 7 is the final computation required to determine the minimum hourly service labor rate that John Ohm must charge his customers to realize 20 percent profit on service labor sales before taxes. Dividing the required annual service labor revenue (\$71,031) by the number of productive manhours John can expect to charge direct to customers produces a minimum hourly service labor charge of \$12.33. If John charges any less than this amount, it will reduce the amount of profit he will realize from his business.

Competitive Pricing

At this point we have established John Ohm's **minimum** hourly service labor charge, which is dependent on the following factors relating to his business:

- Cost of service labor
- Operating, general and administrative expenses
- Desired profit
- Labor recovery rate

The **maximum** hourly service labor rate that John can charge depends on the prices charged by his **local** competitors. If the **minimum** hourly rate he must charge is **equal to or below** the hourly rates of other service shops in his market area, he is in a good competitive position, provided the **quality** of service offered by his shop also is equal to or better than that offered by his competitors. If his rates are below those of other service shops in his area, he can either keep his prices at the minimum level to at-

tract more volume and expand his operation, or he can raise his prices to that of his competitors and realize even more profit from the same volume of business. In either case, his service labor charge will be realistic in terms of his costs and desired profit.

However, if the **minimum** he must charge is substantially **higher** than the rates charged by his competitors, he somehow must lower his rates to remain competitive. In this case, his two most effective choices are:

- reduce costs
- improve productivity (labor recovery rate)

Because the most costly factor of his operation, service labor, is directly proportional to the volume potential of his business, and because many of his other expenses are relatively fixed and cannot be reduced, directly reducing costs probably will be the least effective of the two choices. Thus, he must concentrate on improving his labor recovery rate, or the productivity of his shop.

Fig. 8 shows how John Ohm's labor recovery rate affects his minimum hourly service labor charge. By increasing his labor recovery rate from 80 to 90 percent, he can reduce his minimum hourly charge nearly \$1.50, and still realize the same profit.

Accurate Operating Records—A Must for Profitable Pricing

The foregoing example of how a service shop owner can compute with reasonable accuracy the minimum hourly service labor rate he must charge clearly illustrates the need for accurate and timely accounting of data relating to the following aspects of his business:

- Service labor costs (including all payroll expenses)
- Operating, general and administrative expenses
- Labor recovery (percentage of available manhours actually charged to customers)

(In a future article in this series, we will examine a proven accounting system that will provide the service shop owner the operating data necessary for accurately computing his minimum service labor charge.) ▲



DECISION MAKER

The Sencore CRT Champion. Judge and jury when it comes to color CRT analyzing. Reaches a verdict in seconds — tells you if the tube has adequate emission, and if it will track in the TV set.

Automatic color tracking according to industry standards with exclusive 3 Gun G2 Control.

One-step controlled rejuvenation with automatic RC timer. A Sencore exclusive.

Lots more, too. So try the decision maker — the Sencore CRT Champion — at your distributor today. You'll reach the right verdict.CR143...\$119.50

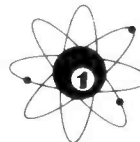

SENCORE

NO. 1 MANUFACTURER OF ELECTRONIC MAINTENANCE EQUIPMENT

426 SOUTH WESTGATE DRIVE, ADDISON, ILLINOIS 60101

Circle 9 on literature card

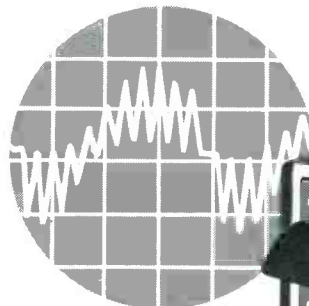

Standard RCA "S" Curve

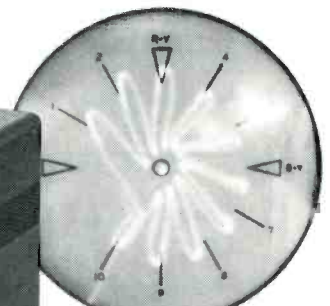

Vector Pattern

DOUBLE



FEATURE

PS148A OSCILLOSCOPE • VECTORSCOPE

With NEW "Triggered Action" sync.

Guaranteed to lock in composite video waveforms faster than a triggered scope or your money returned.

- High sensitivity wide band oscilloscope.
- Professional 5-inch vectorscope. Converts at the flick of a switch in the rear.
- Equips you for every servicing job—complete for color servicing.
- Outstanding flexibility—ideal for field engineering and production line testing.

A Sencore Top Performer, only \$269.50 All Domestic Made

IN STOCK AT YOUR LOCAL PARTS DISTRIBUTOR.



SENCORE

NO. 1 MANUFACTURER OF ELECTRONIC MAINTENANCE EQUIPMENT

3200 Sencore Drive, Sioux Falls, South Dakota 57100

Circle 10 on literature card

Chassis—Motorola TS914Y
PHOTOFACT folder—798-2

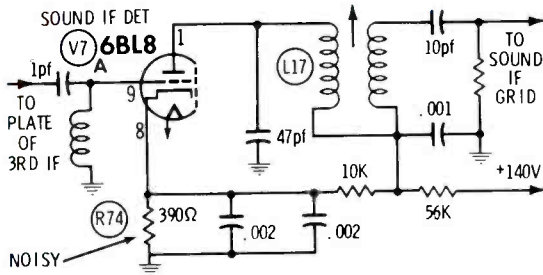

Symptom—intermittent crackling noise in sound
Cure—replace R74, if cathode voltage varies

Chassis—Olympic CTC19 & 21
PHOTOFACT folder—904-3

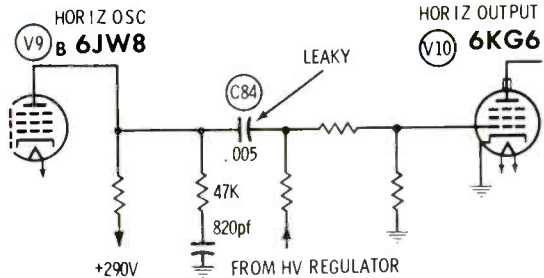

Symptom—poor focus; narrow width; high voltage low
Cure—check coupling capacitor C84 and replace if leaky

Chassis—Magnavox T931
PHOTOFACT folder—984-1

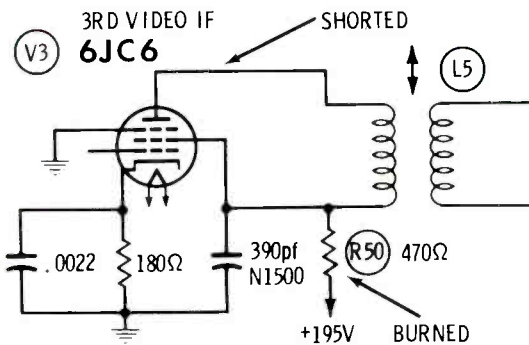

Symptom—no picture; no sound
Cure—check V3; if shorted, replace it and R50

Chassis—Sylvania D06
PHOTOFACT folder—922-3

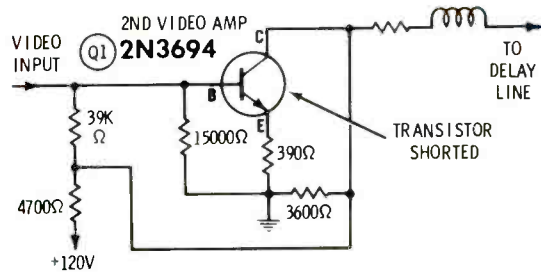

Symptom—negative picture or smear after set is warm
Cure—replace Q1, 2nd video amplifier

Chassis—Motorola TS908
PHOTOFACT folder—721-3

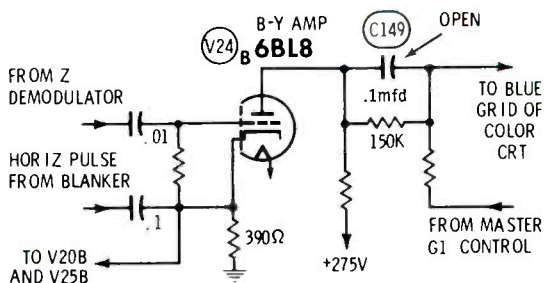

Symptom—left 1/4 of raster is greenish; lack of blue not caused by bad purity
Cure—replace open C149

Chassis—Zenith 16Y6C15
PHOTOFACT folder—983-2

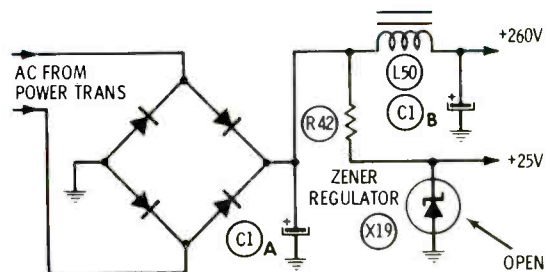

Symptom—two hum bars in picture
Cure—if 25-volt source is high, replace zener regulator X19

**Chassis—Philco 19QT87
PHOTOFACT folder—1026-3**

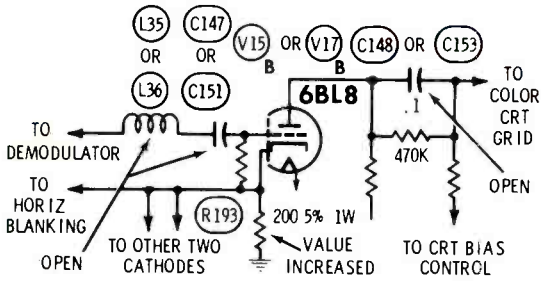

Symptom—loss of blue or red during colorcast; b-w raster is greenish
Cure—check for opens in L35, L36, C151 and C147; replace, if necessary

**Chassis—Philco 19QT87
PHOTOFACT folder—1026-3**

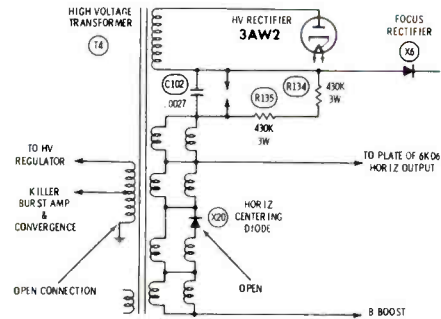

Symptom—no color locking; convergence poor
Cure—resolder the ground to the mounting bracket of T4, the high-voltage transformer

**Chassis—Philco 19QT87
PHOTOFACT folder—1026-3**

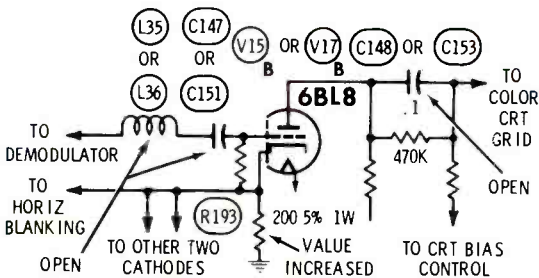

Symptom—gray scale will not track; colors wrong and weak on colorcast; picture too bright
Cure—check and replace R193 (200 ohms), if value has increased

**Chassis—Philco 19QT87
PHOTOFACT folder—1026-3**

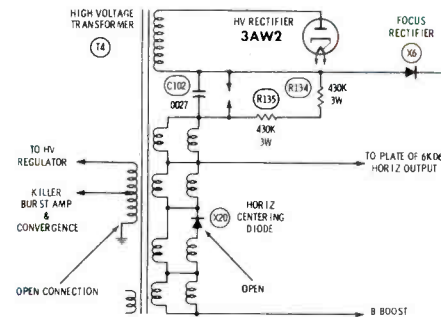

Symptom—picture three inches too far to the right, moves even farther at higher brightness levels
Cure—replace centering diode X20, use power supply type silicon

**Chassis—Philco 19QT87
PHOTOFACT folder—1026-3**

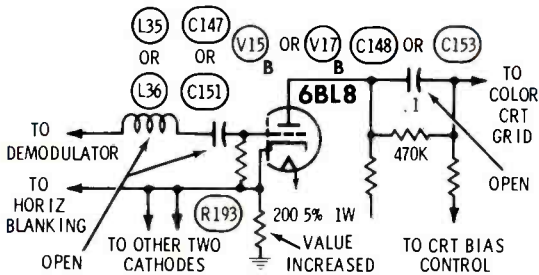

Symptom—loss of blue or red during colorcast; b-w might have color shading on extreme left side
Cure—check for open C148 or C153 in B-Y or R-Y amplifiers

**Chassis—Philco 19QT87
PHOTOFACT folder—1026-3**

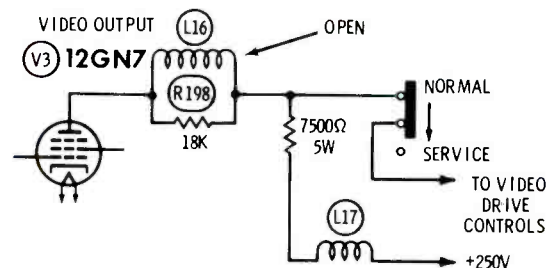

Symptom—white compression; looks like bad CRT
Cure—replace open L16

STEREO TROUBLE— Tuner or Amplifier?

Tips for determining which is the source of the trouble

by Leonard Feldman

Trouble in a high-fidelity component system can occur in either the tuner or amplifier and produce the same audible symptoms. Others are distinctly tuner trouble, and still others are always amplifier troubles. A bit of logical reasoning plus the tips suggested here should reduce your troubleshooting time to the minimum possible.

When most home hi-fi systems consisted of a separate tuner, a pre-amplifier and a power amplifier, it was a fairly simple matter to troubleshoot these systems by the process of elimination. For example, if FM reception failed, but the phonograph section worked, you knew positively that the separate tuner was the cause of the trouble, etc.

Today, the trend in hi-fi stereo equipment is almost exclusively in favor of complete "receivers" (tuner/preamplifier/amplifiers all built on one chassis) or even more consolidated "compact" systems, in which even the record changer is integrated within the one-piece electronic chassis. Functionally, of course, today's chassis is still divided into sections somewhat similar to those of a decade or two ago, but isolation of the offending section becomes a little bit more sophisticated, since we now are dealing with sections common to the whole system (power supply, selector switches, etc.) as well as with isolated circuits and components.

The block diagram in Fig. 1 shows the typical design of all-in-one stereo receivers; with its aid, and using much the same logic you would use in troubleshooting individual components, we shall show how it is still possible to track down troubles in this type of system using the process-of-elimination approach.

Recognizing that **some** enthusiasts of hi-fi still prefer the "separate-component" hi-fi system, we also shall examine problems caused by mismatching separate components.

Harmonic Distortion— Amp or Tuner?

An FM generator, a scope and an audio oscillator are the only test instruments needed to determine which circuit is introducing distortion in a stereo FM system. The FM generator is connected to the an-

tenna terminals, and modulation is set to 75 KHz (100 percent) at an audio frequency of either 400 or 1000 Hz. A scope is connected to the output of the stereo decoder circuitry (either the left or right output, since a mono signal is being used), before the signals are fed on to the preamplifier/amplifier stages.

One form of distortion common to FM circuits is illustrated in the scope photo of Fig. 2. The cause of this distortion is insufficient bandwidth or detector linearity. A wave-shape such as this could **never** be caused by amplifier circuits, which would tend to cause sharp **clipping**, as illustrated in Fig. 3, rather than a "dip" or valley at the tops and bottoms of the sine-wave, as in Fig. 2. Normally, bandwidth of a tuner becomes restricted in this manner in the absence of sufficient signal strength or, what amounts to the same thing, improper RF or IF alignment. If increased signal strength tends to clean up the sine-

Fig. 1 An "integrated" stereo receiver, such as the one diagrammed here, can be analyzed in terms of its separate "component" functions.

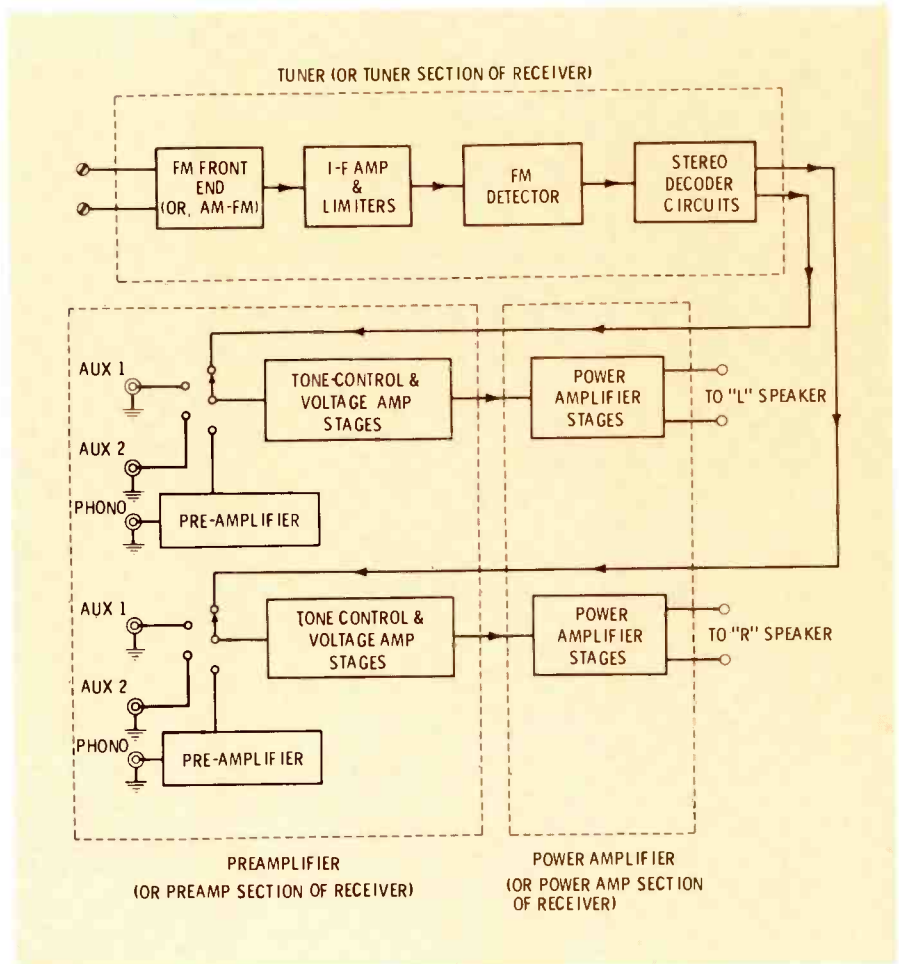

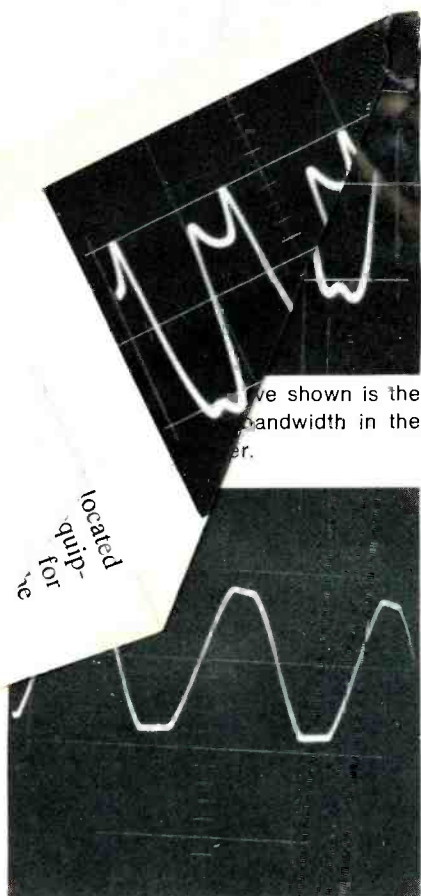

Fig. 3 "Flat-topped" clipping of sine-wave, shown here, is the result of amplifier overloading—not the fault of tuner distortion.

wave of Fig. 2, you can be sure that the cause of the distortion is in the tuner circuits. You then should check alignment and antenna connections and installation. Today's tuners are so "quiet" that a weak signal can cause distorted output without the random noise accompaniment usually associated with weak-signal conditions.

On the other hand, waveshapes such as that of Fig. 3 will seldom be caused by tuner malfunction and are more likely to be the fault of amplifier circuits which are overloaded. A partly shorted speaker connection (frayed lead shorting across the speaker terminals) can reduce power output to the point where the sound is barely audible, and at the same time limit maximum clipping to produce the output shown in Fig. 3. The output of an audio generator fed to the actual amplifier input (in this case of a receiver, use the AUX input) will quickly determine if this condition exists. Apply a signal no greater than that called for in the instruc-

tion manual; most auxiliary inputs require about .5 volt for full amplifier output. Full amplifier output usually will be that power output which results in less than one percent harmonic distortion—an amount of distortion barely visible on a scope presentation (and barely audible, for that matter).

If no distortion is evident when conducting the preceding test, and if no distortion was detected at the output of the tuner section itself, there must exist a mismatch between the tuner and the amplifier. This often happens when a separate tuner and amplifier are used. For example, if the tuner is improperly connected to a low-level input on the amplifier (such as tape head or magnetic phono), the first preamplifier stages of the amplifier might be overloaded by the excessive input signal, though the input signal itself is not distorted and the amplifier is functioning perfectly. To a lesser degree, connecting a tuner whose output is one volt or more to an amplifier input designed to process a signal no greater than 0.5 volt also can cause noticeable distortion, but to a lesser degree.

In the case of "integrated" receivers (tuner/amplifiers), such mismatching is not likely, since the manufacturer has seen to it that output and input levels of the circuits are compatible.

High Hum Level

Most hum problems in high-fidelity component systems occur when magnetic phono cartridges are used. The gain of amplifiers used with magnetic cartridges needs to be about 40 dB greater than the gain in use when FM circuits or other high-level signal sources are applied. Still, there are instances in which hum during FM reception can be a problem.

In separate tuners and amplifiers, hum can be induced in the AFC circuits of the FM front end by electromagnetic coupling of high hum fields. For example, I have encountered tuners mounted directly above the power transformer of an amplifier, and the hum field from the transformer was sufficient to induce hum modulation in the local FM oscillator via the AFC circuits.

If hum is present in all positions of the amplifier's selector switch,

the fault is not in the tuner, but in the amplifier. For this check, don't use the phono position as a reference, but choose a high-level position of the function switch, such as "TAPE IN" or "AUX", whose impedance and gain levels are about equal to that of the tuner input.

Shielded cables between tuner and amplifier should, of course, be examined for open ground connections, or even high-resistance grounds caused by poor soldering at the shell of the pin plugs used with these cables. If removal of the interconnecting cable at the amplifier end stops the hum, suspect the cable or the tuner itself as the source of the trouble. Using a very long interconnecting cable sometimes will induce hum, even if the cable is shielded, because the shielding used in inexpensive audio cable is usually only about 60 to 70 percent effective. If the output of the separate tuner is not fed from a cathode-follower circuit (or an emitter follower, in the case of solid-state equipment), the source impedance will be high, and external hum fields present might cause sufficient voltage drop across the interconnecting cable to produce audible hum.

In the case of all-in-one receivers, the only causes of tuner-section hum I have ever encountered are an open capacitor associated with the power supply that feeds operating voltages to the tuner, and an open RF bypass capacitor in the RF section of the FM tuner.

High Noise Level

Fig. 4 illustrates the relationship between signal and noise in a typical FM tuner. Note that as the input signal strength is increased, the noise level becomes lower and lower, finally reaching a low figure which remains constant. At the same time, the audio output of the tuner section increases in amplitude for a short time with increasing signal, reaching a constant value much sooner than the residual noise reaches its final, low value.

A tuner which exhibits good limiting characteristics will reach this constant level of audio output with just a few microvolts of RF signal applied, while an inferior product might require 100 to 500 microvolts of input signal before the audic

Stack These Up Against The Others

your best buys in meters
come from Heath

For over 20 years, Heath has been the first choice in meters for tens of thousands of service technicians, schools and home labs. There's a reason for this continued popularity — Heath meters are designed to have that balance of versatility, needed features and low cost that make them your best buy. For the price of just a couple of meters from others, you can buy every meter Heath makes. We believe that you should still be able to get a stack of meters without spending a pile of money. When you need a meter, look to Heath. For performance, versatility and top dollar value, the others just don't stack up.

1 \$21.95* Buys A Portable Solid-State Volt-Ohm-Meter. Four ranges on AC & DC volts measure 1-1000 volts full scale. Four resistance ranges measure 0.1 ohm to 1000 megohms. Features convenient battery operation ... zero & ohms adj. controls ... DC polarity reversing switch ... spare jack for HV & RF probes ... rugged polypropylene carrying case. IM-17, 4 lbs.

2 \$31.95* Buys A Portable Volt-Ohm Milliammeter. Measures AC & DC volts 1.5-5000 full scale. DC current from 150 uA to 15A. Resistance midscale from 15-150,000 ohms. Large 4 1/2" 50 uA movement meter for extra accuracy. MM-1, 5 lbs.

3 \$29.95* Buys An Accurate VTVM. 7 AC & DC ranges measure RMS volts from 1.5-15000 full scale ... AC P-P from 4.0-4000 ... 7 resistance ranges from 0.1 ohms to 1000 megohms. 25 Hz — 1 MHz response. Single probe makes all measurements. IM-18, 5 lbs. Assembled IMW-18, 5 lbs. ... \$49.95*

4 \$41.95* Buys A Laboratory AC VTVM. Especially useful for low-level AC & audio work. Ten RMS ranges from 0.01-300 V full scale ... measures dB from -52 to +58. ±1 dB response from 10 Hz-500 kHz. 10 megs. input impedance. IM-38, 4 lbs. Assembled IMW-38, 5 lbs. ... \$49.95*

5 \$39.95* Buys A Big Service Bench VTVM. Has the same high performance as the IM-18 above, plus added features to make it more useful for service work ... separate 1.5 & 5 VAC scales ... calibration controls that are adjustable from the front panel ... versatile gimbal mounting ... large 7" meter. IM-28, 7 lbs. Assembled IMW-28, 7 lbs. ... \$59.95*

6 \$46.95* Buys A Big Solid-State Volt-Ohm Meter. Battery-powered portability plus built-in AC supply. 8 AC & DC ranges 0.5-1500 full scale ... 7 resistance ranges (10 ohm center scale) x1-x1 meg. High input impedance & 6" meter for greater accuracy. IM-16, 10 lbs. Assembled IMW-16, 11 lbs. ... \$69.95*

7 \$85.00* Buys A Deluxe Solid-State Volt-Ohm Milliammeter. 9 AC & DC ranges from 150 mV-1500 V full scale ... 7 resistance ranges measure from 1 ohm to 1000 megohms ... 11 current ranges from 15 uA-1.5 A full scale. 100 kHz response ... high input impedance ... large 6" meter with zero center. IM-25, 10 lbs. Assembled IMW-25, 10 lbs. ... \$120.00*

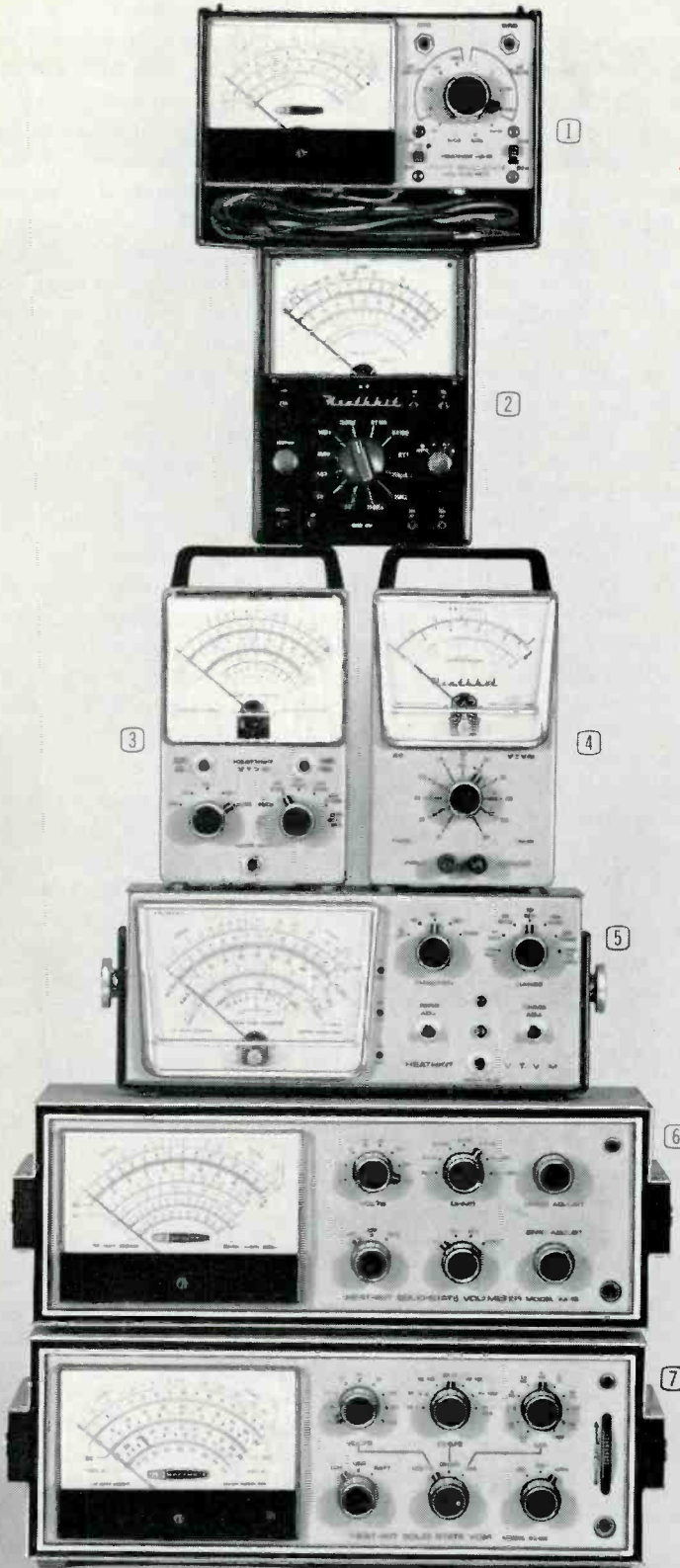

NEW FREE 1970 CATALOG!

Now with more kits in more color. Fully describes these along with over 300 kits for stereo/hi-fi, color TV, electronic organs, guitar amplifiers, amateur radio, marine, educational, CB, home & hobby. Mail coupon or write Heath Company, Benton Harbor, Michigan 49022.

HEATH COMPANY, Dept. 25-7
Benton Harbor, Michigan 49022

Enclosed is \$ _____, plus shipping.

Please send model (s)

Please send FREE Heathkit Catalog.

Please send Credit Application.

Name _____

Address _____

City _____

State _____

Zip _____

*Mail order prices; F.O.B. factory.

Prices & specifications subject to change without notice.

TE-221



a Schlumberger company

Circle 11 on literature card

Some elaborate preamplifiers, and even integrated amplifiers, also are equipped with input-level controls used to set up equal levels from all signal sources. If the amplifier in question is so equipped, the setting of this control might have been moved accidentally and should be checked. Of course, if levels of associated signal sources, such as phono and tape, are suddenly lower than normal, the fault might be traced to the amplifier circuits, using normal audio signal-tracing techniques. Stereo amplifiers are actually an aid in this sort of tracing, since, in most cases, only one channel of the pair will exhibit loss of gain (unless the common power supply is at fault). By comparing the gain at similar points in the circuit of one channel with that of the other channel, the point of gain-loss is quickly determined.

Intermittent FM

The bane of the serviceman's existence, the elusive intermittent, occurs in stereo tuners just as it does in every other piece of consumer electronic equipment. Don't blame the FM tuner, however, until you have checked the amplifier for intermittents by playing through it a signal source other than FM. A good way to isolate the intermittent is to feed a modulated FM RF signal in at the antenna terminals

and observe the scope waveform at the detector output of the FM tuner. A diagram of this setup is shown in Fig. 6. If the intermittent does **not** show up during this observation (while tapping the chassis, applying heat or coolant to the suspected part, etc.), it is reasonable to assume that the trouble is beyond this point, either in the stereo decoder circuitry (which is usually "in-circuit", even in the "mono" mode of operation) or in an early audio amplifying stage in a complete receiver. If it **does** show up, the next step is to feed a modulated 10.7-MHz signal to the 1st IF stage, using a suitable coupling capacitor. If the intermittent disappears under these conditions, the trouble is probably in the RF or oscillator stages of the tuner. A suspicious element is always the variable capacitor, whose rotor might be touching the stator at one or more points during rotation. If the intermittent still is present, the IF section should be suspected; the elements most likely to be at fault are interstage transformers, which can be internally shorted or so close to being shorted that a slight movement of the chassis completes the short.

It Must Be The Tuner

Some common defects in a high-fidelity stereo system immediately

can be pinned down as being the fault of the tuner section (in a tuner/amplifier receiver) or the tuner (in a separate-component system). These include loss of sensitivity, drift, an undue amount of background noise when listening to stereo FM, and permanent or intermittent loss of stereo separation when listening to stereo FM.

Once loss of sensitivity has been established as **not** being caused by a broken antenna connection or a damaged antenna, look in the RF section of the tuner. A weak RF stage (tube or even transistor) will not cause complete absence of reception but will, in most instances, result in a weak, noisy FM signal. Often, an IF stage that is defective will cause the same effect.

Isolation of the exact stage at fault can be accomplished by conducting stage-gain measurements, but these measurements are a bit too complex for some technicians, and require very careful metering and scope observations.

An indirect way to measure early stage gain in a tuner or receiver is by means of the AGC circuits of the tuner or receiver. The setup is shown in block-diagram form in Fig. 7. If, for example, it takes 100 microvolts of RF signal input to produce 2 volts of AGC voltage, and it takes 1000 microvolts of 10.7-MHz IF signal applied to the 1st IF stage to produce the same 2 volts of AGC, then the gain of the "front end" must be 10, or 20 dB of voltage gain.

Similar measurements can be made from stage to stage, using a fixed amount of developed AGC voltage as a reference. If, when moving the signal generator from one stage to the succeeding one, no change in signal input is required to maintain the same AGC voltage, that stage is not producing any gain. Of course, such measurements cannot be used for stages which follow the point from which AGC voltage is derived, such as the last IF or limiter stage, but if you've gotten that far and no stage has been suspected, the last stages can be investigated by process of elimination.

Invariably, a relatively large amount of noise on stereo FM (compared to mono FM) is **not the fault** of the tuner, although it usually is hard to convince your customers of

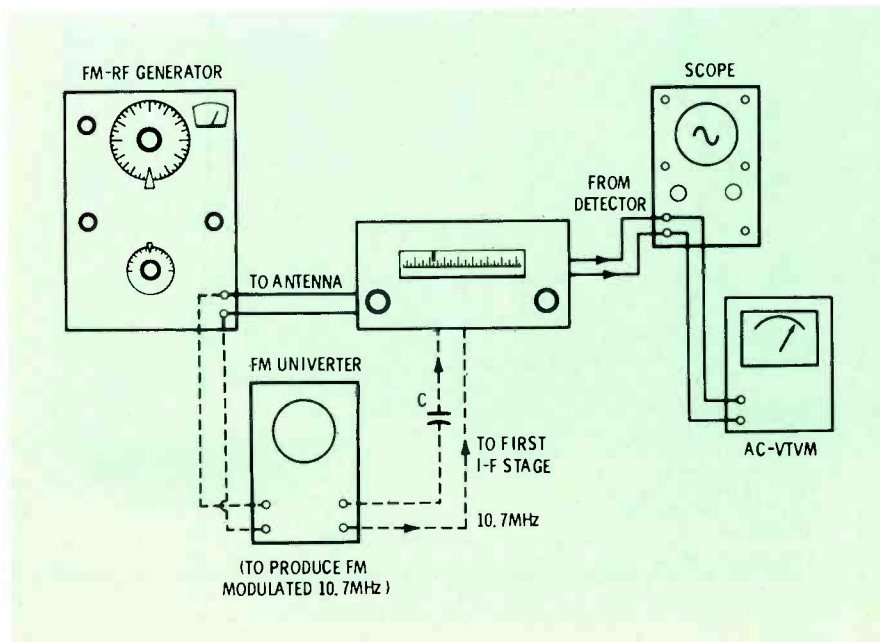

Fig. 6 Test setup for analyzing performance of tuner section in a stereo high-fidelity system.

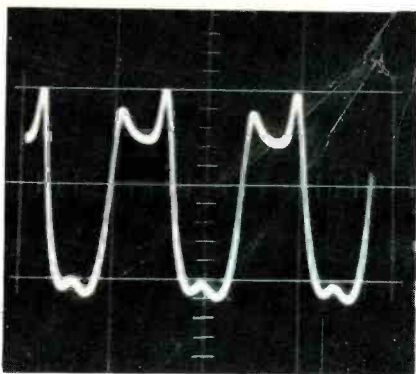

Fig. 2 Distorted sine-wave shown is the result of compressed bandwidth in the IF section of the tuner.

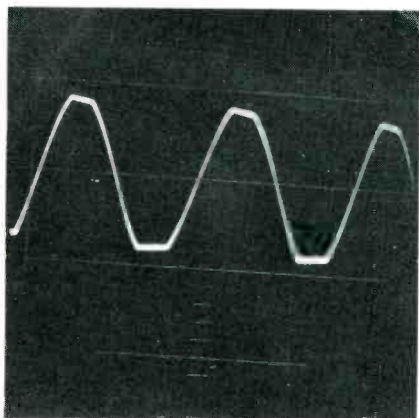

Fig. 3 "Flat-topped" clipping of sine-wave, shown here, is the result of amplifier overloading—not the fault of tuner distortion.

wave of Fig. 2, you can be sure that the cause of the distortion is in the tuner circuits. You then should check alignment and antenna connections and installation. Today's tuners are so "quiet" that a weak signal can cause distorted output without the random noise accompaniment usually associated with weak-signal conditions.

On the other hand, waveshapes such as that of Fig. 3 will seldom be caused by tuner malfunction and are more likely to be the fault of amplifier circuits which are overloaded. A partly shorted speaker connection (frayed lead shorting across the speaker terminals) can reduce power output to the point where the sound is barely audible, and at the same time limit maximum clipping to produce the output shown in Fig. 3. The output of an audio generator fed to the actual amplifier input (in this case of a receiver, use the AUX input) will quickly determine if this condition exists. Apply a signal no greater than that called for in the instruc-

tion manual; most auxiliary inputs require about .5 volt for full amplifier output. Full amplifier output usually will be that power output which results in less than one percent harmonic distortion—an amount of distortion barely visible on a scope presentation (and barely audible, for that matter).

If no distortion is evident when conducting the preceding test, and if no distortion was detected at the output of the tuner section itself, there must exist a mismatch between the tuner and the amplifier. This often happens when a separate tuner and amplifier are used. For example, if the tuner is improperly connected to a low-level input on the amplifier (such as tape head or magnetic phono), the first preamplifier stages of the amplifier might be overloaded by the excessive input signal, though the input signal itself is not distorted and the amplifier is functioning perfectly. To a lesser degree, connecting a tuner whose output is one volt or more to an amplifier input designed to process a signal no greater than 0.5 volt also can cause noticeable distortion, but to a lesser degree.

In the case of "integrated" receivers (tuner/amplifiers), such mismatching is not likely, since the manufacturer has seen to it that output and input levels of the circuits are compatible.

High Hum Level

Most hum problems in high-fidelity component systems occur when magnetic phono cartridges are used. The gain of amplifiers used with magnetic cartridges needs to be about 40 dB greater than the gain in use when FM circuits or other high-level signal sources are applied. Still, there are instances in which hum during FM reception can be a problem.

In separate tuners and amplifiers, hum can be induced in the AFC circuits of the FM front end by electromagnetic coupling of high hum fields. For example, I have encountered tuners mounted directly above the power transformer of an amplifier, and the hum field from the transformer was sufficient to induce hum modulation in the local FM oscillator via the AFC circuits.

If hum is present in all positions of the amplifier's selector switch,

the fault is not in the tuner, but in the amplifier. For this check, don't use the phono position as a reference, but choose a high-level position of the function switch, such as "TAPE IN" or "AUX", whose impedance and gain levels are about equal to that of the tuner input.

Shielded cables between tuner and amplifier should, of course, be examined for open ground connections, or even high-resistance grounds caused by poor soldering at the shell of the pin plugs used with these cables. If removal of the interconnecting cable at the amplifier end stops the hum, suspect the cable or the tuner itself as the source of the trouble. Using a very long interconnecting cable sometimes will induce hum, even if the cable is shielded, because the shielding used in inexpensive audio cable is usually only about 60 to 70 percent effective. If the output of the separate tuner is not fed from a cathode-follower circuit (or an emitter follower, in the case of solid-state equipment), the source impedance will be high, and external hum fields present might cause sufficient voltage drop across the interconnecting cable to produce audible hum.

In the case of all-in-one receivers, the only causes of tuner-section hum I have ever encountered are an open capacitor associated with the power supply that feeds operating voltages to the tuner, and an open RF bypass capacitor in the RF section of the FM tuner.

High Noise Level

Fig. 4 illustrates the relationship between signal and noise in a typical FM tuner. Note that as the input signal strength is increased, the noise level becomes lower and lower, finally reaching a low figure which remains constant. At the same time, the audio output of the tuner section increases in amplitude for a short time with increasing signal, reaching a constant value much sooner than the residual noise reaches its final, low value.

A tuner which exhibits good limiting characteristics will reach this constant level of audio output with just a few microvolts of RF signal applied, while an inferior product might require 100 to 500 microvolts of input signal before the audio

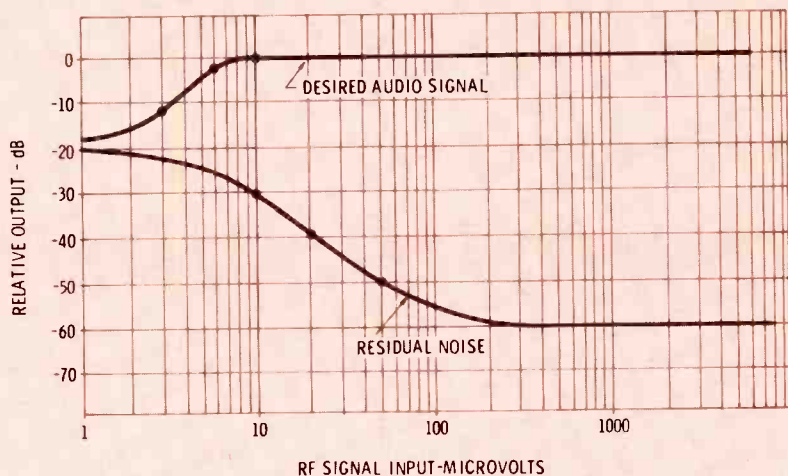

Fig. 4 FM background noise and audio output levels are a function of input (RF) signal strength, and follow the general relationships shown in the curves.

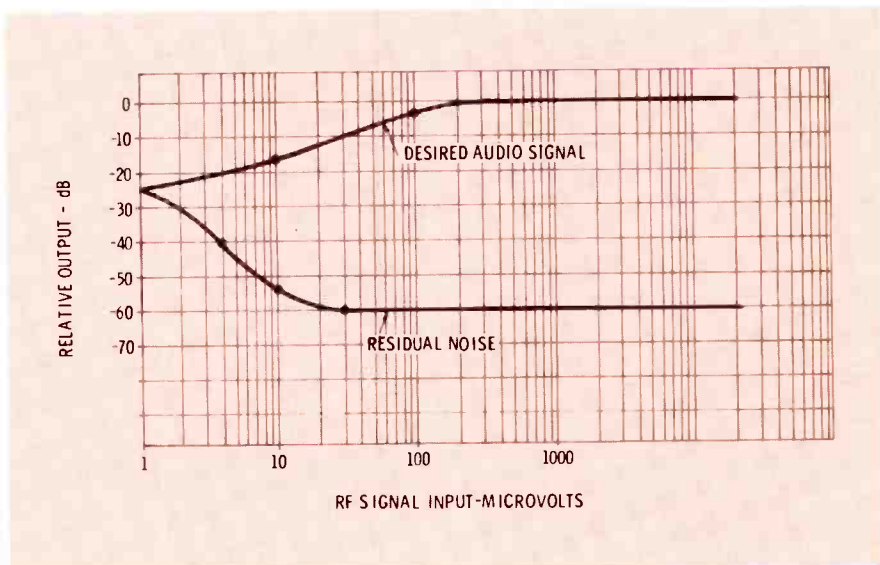

Fig. 5 In some tuner circuits, adequate "quieting" is reached at signal levels which are too low to provide "full limiting", or "full audio recovery".

"plateau" is reached. This explains how a weak signal can produce background noise, even though the audio level appears normal. For example, note that while a signal of 10 microvolts will produce full output of audio in the example of Fig. 4, the noise at this signal input level will be only some 30 dB below full output, and, therefore, quite audible and annoying.

If noise is traced to the tuner itself (by checking for other noise forms in the phono or other amplifier input positions and noting its absence), you probably will be dealing with a signal strength problem (although resistors and transistors in these circuits can produce noise).

Again, this will require investigation of antenna connections, the condition of the antenna (is it rusted, are transmission line connections good, etc.?) as well as the alignment of the tuner. If the set under investigation is equipped with any kind of signal-strength meter, it can be used to check the strength of the received signal. Using an FM generator having an output calibrated in microvolts, you can easily calibrate the tuner's own signal strength meter to read directly in microvolts. For example, if you establish that 20 microvolts of input signal from your generator will cause the tuning meter to deflect two divisions, and a radio station signal causes a

meter deflection of only one division, you know that the received signal is considerably less than 20 microvolts—too weak to produce quiet operation.

Background FM noise is "white noise", or noise that contains all audible frequencies. Noise produced by noisy transistors, resistors and tubes usually has a more characteristic "shot" noise effect; with practice, you might be able to distinguish between the two types just by listening. In the event that you do decide that a noisy transistor is at fault, it usually will be one located in the audio portion of the equipment, since transistors designed for use at high frequencies (such as the 10.7-MHz IF and 100-MHz region RF associated with FM) are generally much lower-noise devices to begin with, and are subjected to greater quality control with regard to this parameter.

It's Not Loud Enough

Fig. 5 shows that under certain conditions a signal can be received with adequate quieting (absence of background noise) but so far below limiting that it is necessary to turn up the volume control more than for other received signals. This will occur in weak signal areas when you are dealing with a set that has very poor limiting. It has been my experience that many foreign-made sets suffer from this defect, because the designers place greater emphasis on noise quieting than on good listening.

Obviously, you cannot redesign these sets, but you can determine, as before, that the signal is weak and then do something to improve the audio recovery, such as installing a better antenna or, if no antenna is being used at all (other than a short piece of wire or a so-called line-cord-coupled antenna), strongly recommend to your customer that a suitable FM antenna be installed.

In the case of separate tuners connected to separate amplifiers, make certain that the low FM level is not being caused by a misadjustment of the level control usually supplied on the tuner. This control might or might not be a front-panel control. Often, it is a rear "screw-driver" control intended to be set properly during installation.

Stack These Up Against The Others

your best buys in meters
come from Heath

For over 20 years, Heath has been the first choice in meters for tens of thousands of service technicians, schools and home labs. There's a reason for this continued popularity — Heath meters are designed to have that balance of versatility, needed features and low cost that make them your best buy. For the price of just a couple of meters from others, you can buy every meter Heath makes. We believe that you should still be able to get a stack of meters without spending a pile of money. When you need a meter, look to Heath. For performance, versatility and top dollar value, the others just don't stack up.

1 \$21.95* Buys A Portable Solid-State Volt-Ohm-Meter. Four ranges on AC & DC volts measure 1-1000 volts full scale. Four resistance ranges measure 0.1 ohm to 1000 megohms. Features convenient battery operation ... zero & ohms adj. controls ... DC polarity reversing switch ... spare jack for HV & RF probes ... rugged polypropylene carrying case. IM-17, 4 lbs.

2 \$31.95* Buys A Portable Volt-Ohm Milliammeter. Measures AC & DC volts 1.5-5000 full scale. DC current from 150 uA to 15A. Resistance midscale from 15-150,000 ohms. Large 4 1/2" 50 uA movement meter for extra accuracy. MM-1, 5 lbs.

3 \$29.95* Buys An Accurate VTVM. 7 AC & DC ranges measure RMS volts from 1.5-15000 full scale ... AC P-P from 4.0-4000 ... 7 resistance ranges from 0.1 ohms to 1000 megohms. 25 Hz — 1 MHz response. Single probe makes all measurements. IM-18, 5 lbs. Assembled IMW-18, 5 lbs. ... \$49.95*

4 \$41.95* Buys A Laboratory AC VTVM. Especially useful for low-level AC & audio work. Ten RMS ranges from 0.01-300 V full scale ... measures dB from -52 to +58. ±1 dB response from 10 Hz-500 kHz. 10 megs. input impedance. IM-38, 4 lbs. Assembled IMW-38, 5 lbs. ... \$49.95*

5 \$39.95* Buys A Big Service Bench VTVM. Has the same high performance as the IM-18 above, plus added features to make it more useful for service work ... separate 1.5 & 5 VAC scales ... calibration controls that are adjustable from the front panel ... versatile gimbal mounting ... large 7" meter. IM-28, 7 lbs. Assembled IMW-28, 7 lbs. ... \$59.95*

6 \$46.95* Buys A Big Solid-State Volt-Ohm Meter. Battery-powered portability plus built-in AC supply. 8 AC & DC ranges 0.5-1500 full scale ... 7 resistance ranges (10 ohm center scale) x1-x1 meg. High input impedance & 6" meter for greater accuracy. IM-16, 10 lbs. Assembled IMW-16, 11 lbs. ... \$69.95*

7 \$85.00* Buys A Deluxe Solid-State Volt-Ohm Milliammeter. 9 AC & DC ranges from 150 mV-1500 V full scale ... 7 resistance ranges measure from 1 ohm to 1000 megohms ... 11 current ranges from 15 uA-1.5 A full scale. 100 kHz response ... high input impedance ... large 6" meter with zero center. IM-25, 10 lbs. Assembled IMW-25, 10 lbs. ... \$120.00*

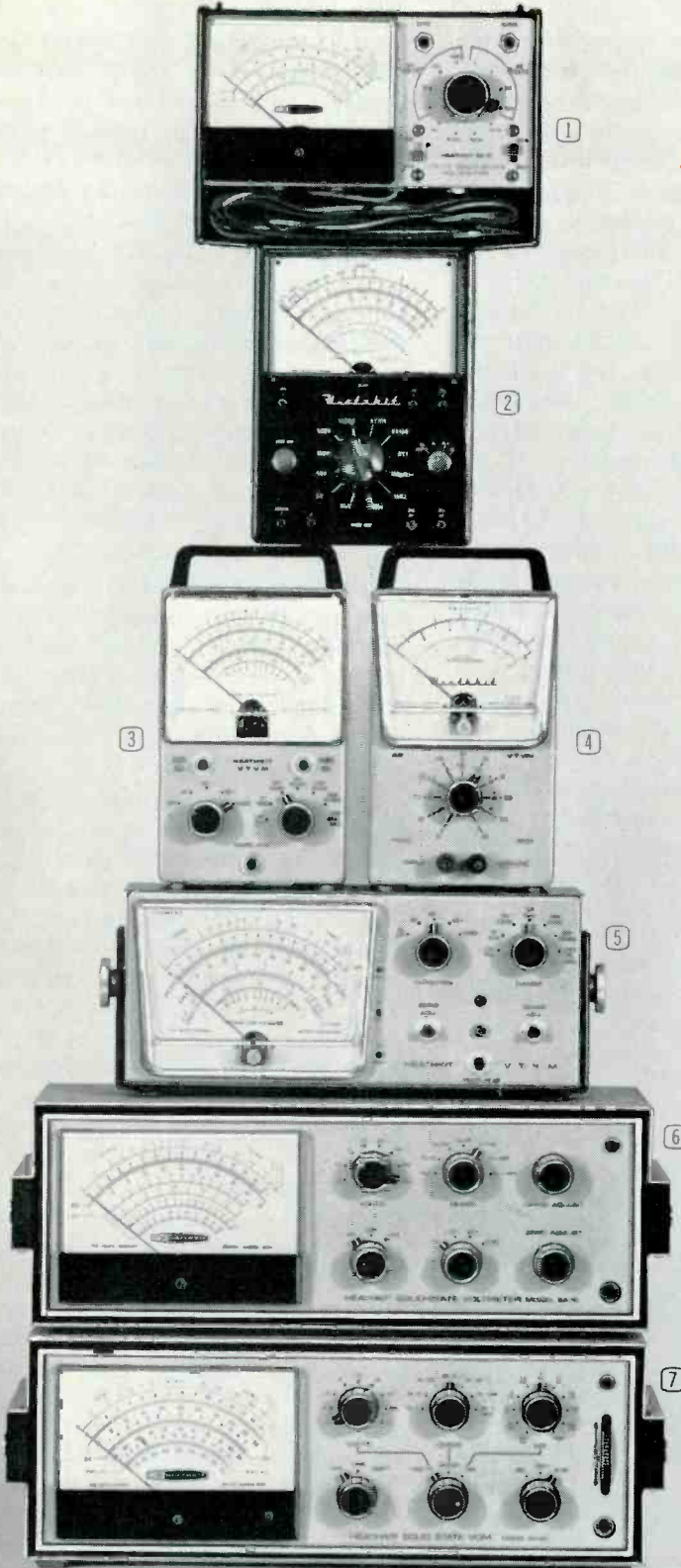

HEATH COMPANY, Dept. 25-7
Benton Harbor, Michigan 49022

a Schlumberger company

Enclosed is \$ _____, plus shipping.

Please send model (s) _____

Please send FREE Heathkit Catalog.

Please send Credit Application.

Name _____

Address _____

City _____

State _____

Zip _____

*Mail order prices; F.O.B. factory.

Prices & specifications subject to change without notice.

TE-221



NEW

FREE 1970 CATALOG!

Now with more kits, more color. Fully describes these along with over 300 kits for stereo/hi-fi, color TV, electronic organs, guitar amplifiers, amateur radio, marine, educational, CB, home & hobby. Mail coupon or write Heath Company, Benton Harbor, Michigan 49022.

Circle 11 on literature card

Some elaborate preamplifiers, and even integrated amplifiers, also are equipped with input-level controls used to set up equal levels from all signal sources. If the amplifier in question is so equipped, the setting of this control might have been moved accidentally and should be checked. Of course, if levels of associated signal sources, such as phono and tape, are suddenly lower than normal, the fault might be traced to the amplifier circuits, using normal audio signal-tracing techniques. Stereo amplifiers are actually an aid in this sort of tracing, since, in most cases, only one channel of the pair will exhibit loss of gain (unless the common power supply is at fault). By comparing the gain at similar points in the circuit of one channel with that of the other channel, the point of gain-loss is quickly determined.

Intermittent FM

The bane of the serviceman's existence, the elusive intermittent, occurs in stereo tuners just as it does in every other piece of consumer electronic equipment. Don't blame the FM tuner, however, until you have checked the amplifier for intermittents by playing through it a signal source other than FM. A good way to isolate the intermittent is to feed a modulated FM RF signal in at the antenna terminals

and observe the scope waveform at the detector output of the FM tuner. A diagram of this setup is shown in Fig. 6. If the intermittent does **not** show up during this observation (while tapping the chassis, applying heat or coolant to the suspected part, etc.), it is reasonable to assume that the trouble is beyond this point, either in the stereo decoder circuitry (which is usually "in-circuit", even in the "mono" mode of operation) or in an early audio amplifying stage in a complete receiver. If it **does** show up, the next step is to feed a modulated 10.7-MHz signal to the 1st IF stage, using a suitable coupling capacitor. If the intermittent disappears under these conditions, the trouble is probably in the RF or oscillator stages of the tuner. A suspicious element is always the variable capacitor, whose rotor might be touching the stator at one or more points during rotation. If the intermittent still is present, the IF section should be suspected; the elements most likely to be at fault are interstage transformers, which can be internally shorted or so close to being shorted that a slight movement of the chassis completes the short.

It Must Be The Tuner

Some common defects in a high-fidelity stereo system immediately

can be pinned down as being the fault of the tuner section (in a tuner/amplifier receiver) or the tuner (in a separate-component system). These include loss of sensitivity, drift, an undue amount of background noise when listening to stereo FM, and permanent or intermittent loss of stereo separation when listening to stereo FM.

Once loss of sensitivity has been established as **not** being caused by a broken antenna connection or a damaged antenna, look in the RF section of the tuner. A weak RF stage (tube or even transistor) will not cause complete absence of reception but will, in most instances, result in a weak, noisy FM signal. Often, an IF stage that is defective will cause the same effect.

Isolation of the exact stage at fault can be accomplished by conducting stage-gain measurements, but these measurements are a bit too complex for some technicians, and require very careful metering and scope observations.

An indirect way to measure early stage gain in a tuner or receiver is by means of the AGC circuits of the tuner or receiver. The setup is shown in block-diagram form in Fig. 7. If, for example, it takes 100 microvolts of RF signal input to produce 2 volts of AGC voltage, and it takes 1000 microvolts of 10.7-MHz IF signal applied to the 1st IF stage to produce the same 2 volts of AGC, then the gain of the "front end" must be 10, or 20 dB of voltage gain.

Similar measurements can be made from stage to stage, using a fixed amount of developed AGC voltage as a reference. If, when moving the signal generator from one stage to the succeeding one, no change in signal input is required to maintain the same AGC voltage, that stage is not producing any gain. Of course, such measurements cannot be used for stages which follow the point from which AGC voltage is derived, such as the last IF or limiter stage, but if you've gotten that far and no stage has been suspected, the last stages can be investigated by process of elimination.

Invariably, a relatively large amount of noise on stereo FM (compared to mono FM) is **not the fault** of the tuner, although it usually is hard to convince your customers of

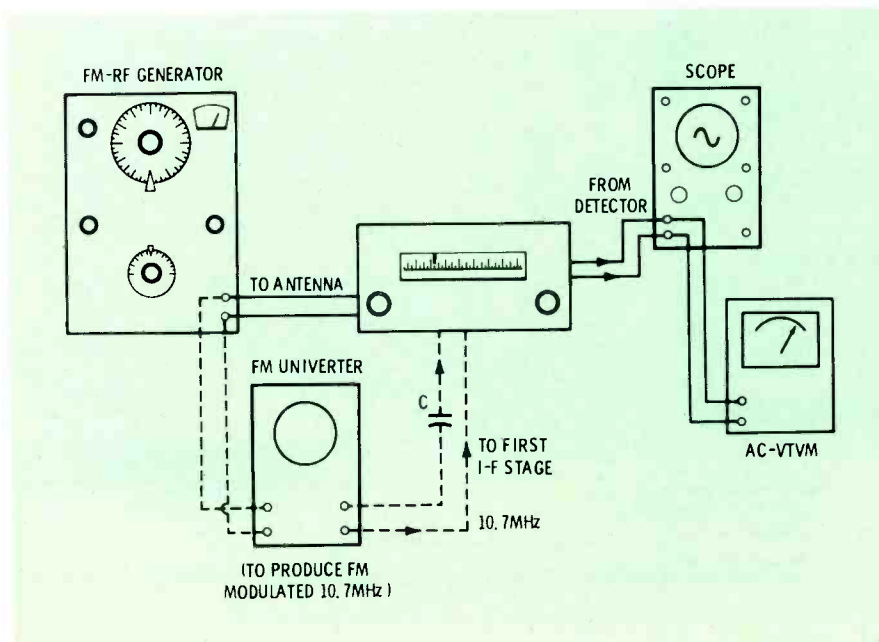

Fig. 6 Test setup for analyzing performance of tuner section in a stereo high-fidelity system.

The hunt is on!

(Beware of the Grope.)

How to keep the Grope from bagging your prospects without them lifting a finger.

The Grope preys on people who don't know where to find what they're hunting for . . . turning their search for you into a jungle hunt.

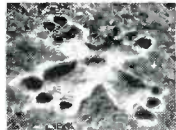

The Grope footprint goes in all directions, like you without the Yellow Pages.

But you can put one over on the Grope, if you don't spread yourself thin. Cover your territories . . . all of them, by listing yourself in the surrounding area Yellow Pages.

You see a lot of your prospects that are nearby, use a nearby Yellow Pages. And when they lift a finger, if you're not there . . . they miss out on you and you on them.

So play it smart and list yourself in the surrounding area Yellow Pages. After all, why try for some of the customers some of the time, when you can try for all of the customers all of the time!



The Yellow Pages

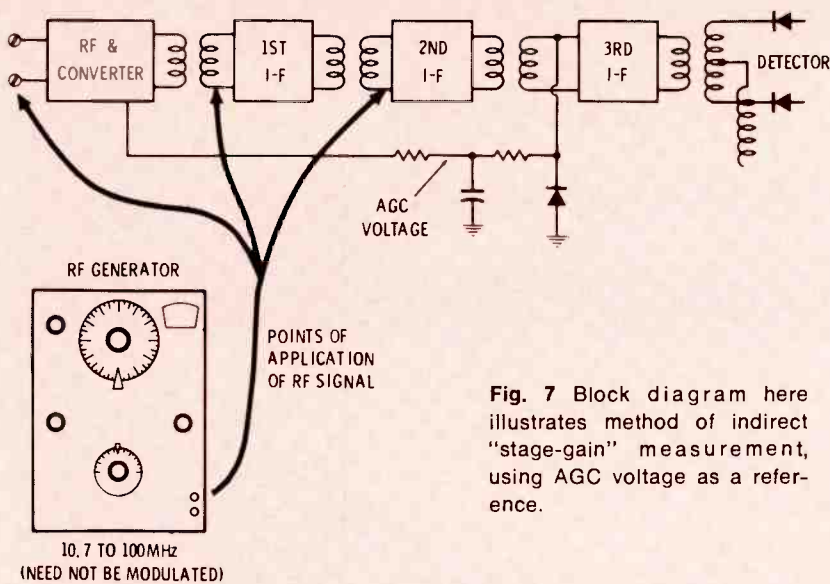

Fig. 7 Block diagram here illustrates method of indirect "stage-gain" measurement, using AGC voltage as a reference.

this fact. The truth is that stereo FM reception is about 20 dB noisier than monophonic FM. A design that produces 60 or 70 dB of signal-to-noise on a strong mono FM signal usually will produce about 40 to 50 dB of signal-to-noise in stereo FM, which is still quite acceptable. But, if a particular design produces 40 or so dB of quieting on a mono signal (which is acceptable), when it is switched to stereo FM, it will yield a 20 dB signal-to-noise ratio, which is definitely **not** acceptable. Since there's nothing you can do to the set design to increase its basic sensitivity, and since you can't ask the customer to move closer to the broadcast station, your only alternative is to sell the customer on the idea of a good outdoor FM antenna suitable for his location and distance from the stations he wants to hear. It's a lot easier (and quite common) to get an increase of signal strength of ten-to-one by using a good outdoor antenna than it is to increase tuner sensitivity by even two-to-one!

Usually, loss of separation in stereo FM is also the result of a weak signal, though other causes, such as faulty stereo decoder or switching circuits, can produce the trouble. Most modern stereo tuners have an automatic switching circuit which changes the reception mode from mono to stereo when a stereo signal is received. Most of these circuits have a "threshold" adjust-

ment, set at the factory to switch the receiver over to the stereo mode at a given signal strength. This is done because most listeners will not want to listen to stereo FM if it is accompanied by an excessive amount of background noise. Your customer might prefer separation—even if it is noisy, so check the stereo threshold adjustment, if the tuner is equipped with one. Of course, if separation is lost for **all** stereo FM listening conditions, the trouble is more serious and the actual multiplex circuits need to be checked (**after** you make certain the customer has not accidentally set a remote mode switch to the "mono" position!).

Gradual drift is almost always caused by heat—heat which reaches frequency-sensitive capacitors, coils and active devices in the local oscillator section of the tuner. Although today's solid-state designs have decreased the probability of drift by reducing heat build-up in the chassis, placing a solid-state tuner directly over a heat-producing amplifier (even a solid-state model) can upset the carefully compensated-for circuits, and can cause drift in even the most modern set.

Tube-type sets should be given plenty of ventilation and air space around them, so that the greater amount of heat produced in these chassis will not cause excessive drift.

Unusual or severe cases of drift usually can be traced to a defective

compensating capacitor associated with the local oscillator circuit of the FM tuner. The active oscillator element (transistor, FET, etc.) also might be at fault, and its voltages should be checked both when cool and an hour or so later, after the set has reached operating temperature. Another remote, but possible, cause of drift in an FM set is extreme change of power line voltage (caused when all the air conditioners are turned on in an inadequately wired house, for example).

It Must Be The Amplifier

A dead stereo channel usually means a dead amplifier channel, but not always. The easiest check is to feed a signal into the AUX input of the amplifier, using both left and right inputs. If the previously dead channel is still inoperative, the trouble is in the amplifier.

As mentioned previously, transistor noise can be mistaken for tuner noise by all but the most experienced listener. Actually, there is a difference. Transistor noise usually (but not always) is laden with a "shot" effect, and usually is not uniform in intensity. Tuner background noise is uniform, wide-spectrum noise, and is not as offensive to the listener. Still, if you're not sure, switch to **AUX** once more. If the noise is still there and similar in character to what you heard when the function switch of the set was in the tuner position, the trouble probably is in the amplifier.

Overheating of amplifier output transistors, blowing of fuses and popping of thermal circuit breakers are all symptoms of an overloaded amplifier. If these failures occur when listening to FM at normal levels, the trouble is in the amplifier and not in the tuner. A check for partial speaker lead shorts or unaudible oscillations, which might be driving the amplifier far into overload without anything being heard, should quickly disclose the source of the trouble. In some class **AB** or class **B** transistorized amplifier circuits, one of the output pair can be defective and the amplifier still produce sound at low or medium levels. However, in such cases, current drain might become excessive because of unbalanced biasing, producing the overload symptoms mentioned previously. ▲

Cut your time

With "QT." The Quick Turnover Parts Inventory System from RCA.

How much time do you spend in the shop searching for parts? And if you don't have them, how long does it take you to get them?

If you're doing more than your share of looking for parts or ordering them on the phone, you're wasting time.

Time that's cutting down your efficiency and preventing you from doing the really important things.

That's where our Quick Turnover Parts Inventory System ("QT" for short) can help.

It's a system that puts 250 of the fastest moving RCA parts for TV sets, radios and phonographs at your fingertips. Parts selected by RCA's computers.

You'll also know when the supply is running low. And should any of the parts be dropped from the "top-mover" list, simply return them through your "QT" distributor.

Talk to your RCA Parts & Accessories Distributor about putting in a "QT" Inventory System.

The sooner you do the faster you'll start saving time.

RCA Parts and
Accessories

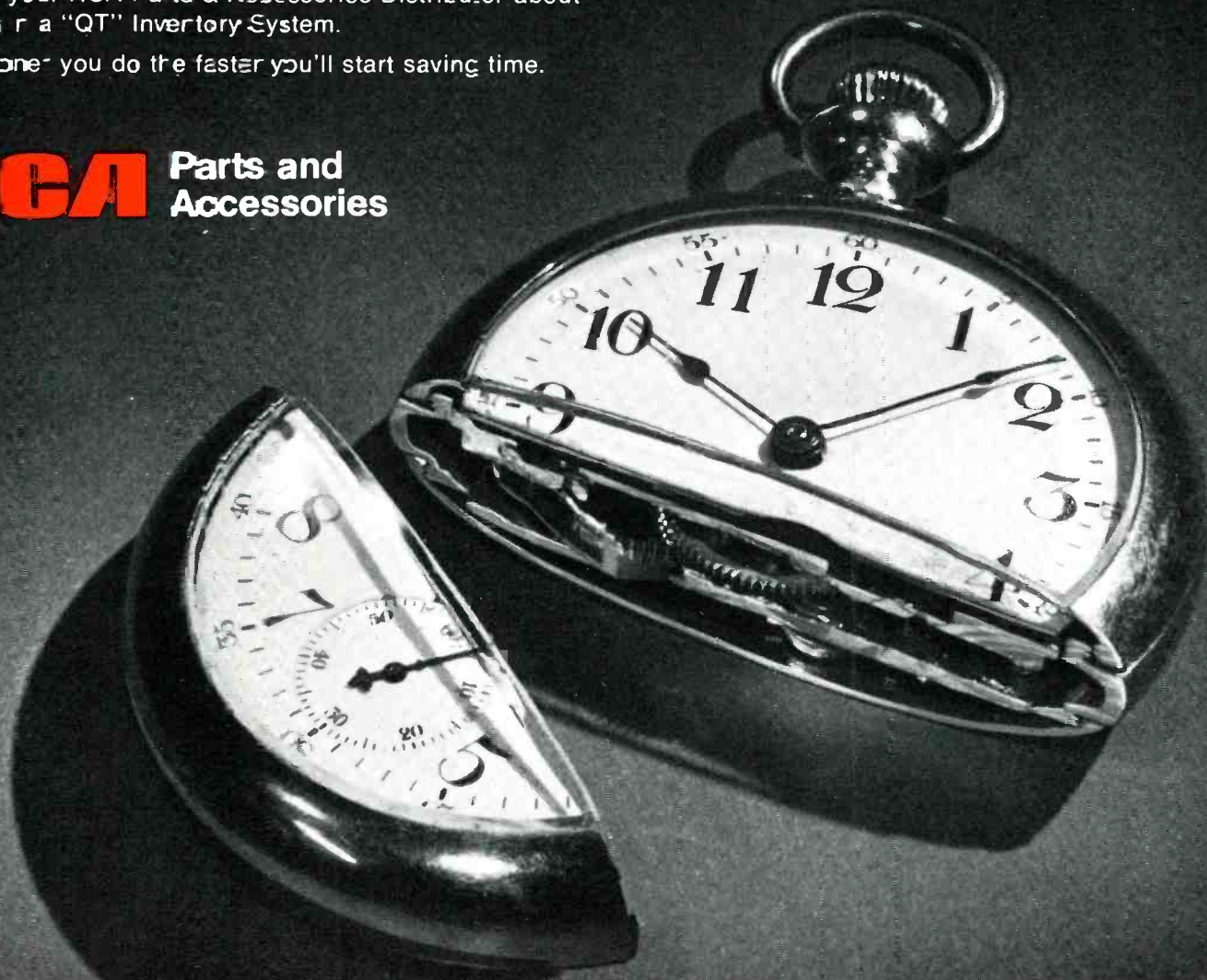

NEW
TV/radio/Hi Fi
fix-it
tools

make tricky jobs easy

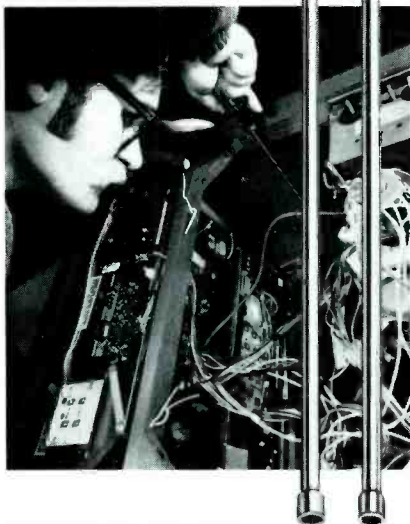

SUPER LONG NUTDRIVERS

Over 20" long with 1/4" and 5/6" hex openings, color-coded plastic (UL) handles, full length hollow shafts.

Eliminate skinned knuckles and the frustration of trying to reach tuners, bezels, other up-front components from the back of a TV set with ordinary tools.

Extra length means more convenience, greater driving power for many other "fix-it" jobs.

INVERTED PALNUT DRIVER SHANKS

Fit all Xcelite "99" handles, including Tee and ratchet types. Popular 7/16" and 1/2" external hex sizes, hollow shanks.

Save time, prevent damage to fastener or equipment when removing Palnuts on balance controls, on-off switches, volume control shafts of most TV sets, record players, portable radios.



*nationwide availability through
 local distributors*

REQUEST BULLETIN N470



XCELITE INC., 18 BANK ST., ORCHARD PARK, N. Y.
 In Canada contact Charles W. Pointon, Ltd.

Circle 13 on literature card

test equipment
report

Multimeter Checks Resistance In-Circuit

A new "Hi-Lo" multimeter that will check resistances in-circuit has been announced by Sencore.

Model FE20 powers the ohms section of the meter with a conventional 1.5-volt "C" cell battery for checks of conductivity of transistors, diodes and rectifiers, enabling the user to check front-to-back ratios.



The function switch can be set to "Lo" ohms, powering the ohms section with less than .10 volt, allowing the user to measure resistances in-circuit without the solid-state device conducting and causing erroneous readings. Both "Hi" and "Lo" ohms are read on the same scale.

A high-voltage probe is provided with each multimeter, to extend the voltage range to 30,000 volts. A low-voltage probe with isolation resistor also is provided to prevent loading of high-frequency circuits.

This portable unit requires no external power, and shuts off automatically when the cover is closed, to prevent draining the battery when not in use. The ranges include: nine DC ranges; three high-voltage ranges; nine AC ranges; seven resistance ranges, with 12-ohms center scale and 1000 megohms maximum; nine DC current ranges, up to 1 amp. Input impedances are 15 megohms DC input and 18 megohms AC.

Accuracy is 1.5 percent on DC and 3 percent on AC. The price is \$129.50.

Circle 50 on literature card

Solid-State Oscilloscope

A solid-state oscilloscope, which has a 3-inch screen with a DC bandwidth to 7 MHz, has been made available by Leader Instruments.

Leader reports that special input circuitry stabilizes the DC level so that power line fluctuations will not affect the position of the CRT display. The unit has an input sensitivity of 10 mv/cm, and can be adapted for use as a vectorscope.

The calibration voltage is set at 0.03 volt p-p at line frequency. The sweep circuit has a frequency range of 1 Hz to 200 KHz in 6 steps, and reportedly locks automatically to



the horizontal video pattern of the television signal.

Power is 105-125 volts, 50-60 Hz. The Model LBO-32B measures 9 inches X 6 3/4 inches X 10 1/2 inches, weighs 17.6 lbs. and costs \$189.50.

Circle 51 on literature card

Digital Multimeter

A solid-state, 3 1/2-digit, table-top digital multimeter, designed to measure DC voltage and current, resistance and rms values of sinusoidal voltages and currents, has been made available by Triplet Corp.

Model 8000 reportedly has virtually no internally generated current for the VOM input circuit, allowing voltage measurements in high-

resistance circuits at the stated accuracy. It also has protective circuitry which prevents damage to the tester when voltages up to 1000 volts AC or DC are applied at the inputs on any of the selectable voltage ranges. The sample rate is 6 times per second.

Measurements are displayed in the decimal number system by three gas-filled readout tubes. Also, the numeral "1" is displayed for over-range measurements. The readout



display is complete with a movable decimal point, automatic over-range indication and automatic polarity selection on DC functions.

DC voltmeter ranges are: 0-0.1, 1.0, 10, 100 and 1000 volts DC. The accuracy is ± 0.1 percent of

reading ± 1 digit. The temperature coefficient (0 to 40 degrees C) is ± 0.01 percent per degree C. The input resistance is 10 megohms on all ranges. AC voltmeter ranges are: 0-0.1, 1.0, 10, 100 and 1000 volts AC. The accuracy at 50 to 20-KHz frequency is ± 0.2 of reading ± 1 digit. Ohmmeter ranges are: 100, 1K, 10K, 100K, 1 megohm and 10 megohms. The accuracy is ± 0.2 percent of reading ± 1 digit.

Current measurement (AC and DC) ranges are: 10 μ a, and 0.1, 1.0, 10, 100 and 1000 ma. Accuracy is ± 0.2 percent of DC reading and ± 0.4 percent of AC reading ± 1 digit from 100 Hz to 10 KHz. Full-scale circuit voltage drop is 100 mv AC or DC on all ranges.

Power source is 115 ± 10 volts AC or 230 ± 20 volts AC, 50/60 Hz, 12 watts.

A stored metal leg is provided to elevate the front edge approximately 25 degrees to facilitate table-top use. Model 8000 measures 4 $\frac{1}{8}$ inches X 10 $\frac{1}{8}$ inches X 8 $\frac{7}{8}$ inches, weighs 9 $\frac{1}{4}$ lbs. and sells for \$575.00.

Circle 52 on literature card

Tube Tester

Mercury Electronics Corp. has introduced the Model 1101C grid-circuit analyzer tube tester, which

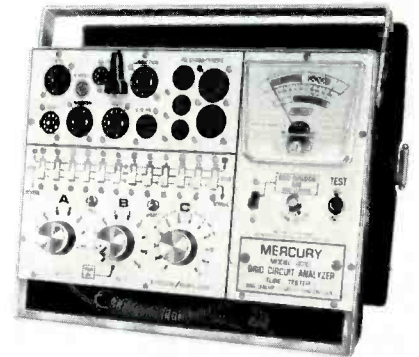

incorporates built-in VTVM circuitry.

Up-to-date sockets are provided, with a wide range of filament voltages and eight individual selections of load voltages included. Tube test data is kept permanently up to date. The unit weighs 7 lbs. and is housed in a luggage-type carrying case.

The price is \$69.95 factory wired. ▲

Circle 53 on literature card



FREE CATALOG



C.R.T. EQUIPMENT COMPANY

TV PICTURE TUBE REBUILDING EQUIPMENT

C.R.T. Equipment Company, Inc.
2740 Old Lebanon Road
Nashville, Tennessee 37214

Telephone (615) 883-0215

Mail Coupon Today

(Please Print)

Name _____

Firm Name _____

Address _____

City _____ State _____ Zip _____

Clip Me Out

Circle 14 on literature card

How video IF and chroma bandwidth affects picture quality

Robert G. Middleton

Poor picture quality can be caused by defects anywhere in the video signal channel. However, sub-normal video IF bandwidth is the most likely cause, because most of the gain and selectivity of the receiver is contributed by the video IF amplifier.

A typical transistor video IF section, employing four tuned collector-load circuits and two traps, is shown in Fig. 1. (The first tuned load is located in the tuner.) Note that the first and third stages are neutralized, and that the second stage includes a negative-feedback loop. Defects in neutralizing, or negative-feedback, branches can make it impossible to obtain correct IF alignment.

How poor IF bandwidth affects picture quality is discussed in the following paragraphs.

Low and High Video Frequencies

We know that a square wave or pulse is developed by combining high- and low-frequency sine waves, as depicted in Fig. 2. When an IF amplifier has full 3-MHz bandwidth, as shown in Fig. 1, both high- and low-video frequencies are passed without discrimination, and a square-wave signal with sharp edge definition is reproduced on the picture-tube screen, as shown in Fig. 3. If the video IF bandwidth is only a fraction of 3 MHz, the low video frequencies are passed, but the high video frequencies are attenuated or rejected, and a square-wave signal with fuzzy edges is reproduced on the picture-tube screen as shown in Fig. 4.

A TV sync pulse is formed from rectangular waves. When the IF bandwidth is normal, a waveform like that in Fig. 5A will be produced. However, as the bandwidth is narrowed, the higher-frequency components are attenuated or eliminated from the waveform, and the

sync pulse becomes progressively "feathered", and its amplitude reduced. This form of distortion introduces both curvature and tilt into the original flat top of the pulse waveform. Curvature results from loss of the higher harmonics. Tilt results from non-linear phase. Let us see how the phase of a tuned IF circuit varies with frequency.

Fig. 6 shows how the phase characteristic of a simple parallel-resonant circuit causes the current to lag the voltage at low frequencies and lead the voltage at high frequencies. This fact by itself is not a matter for concern, because we are restricting ourselves to voltage waveforms, not current. What is important is the **nonlinearity** of the phase characteristic shown in Fig. 6. If the phase characteristic were a straight line, there would be no phase distortion of voltage waveforms. Since the characteristic is curved, the phases of high- and low-frequency components are shifted unequally, with the result that the

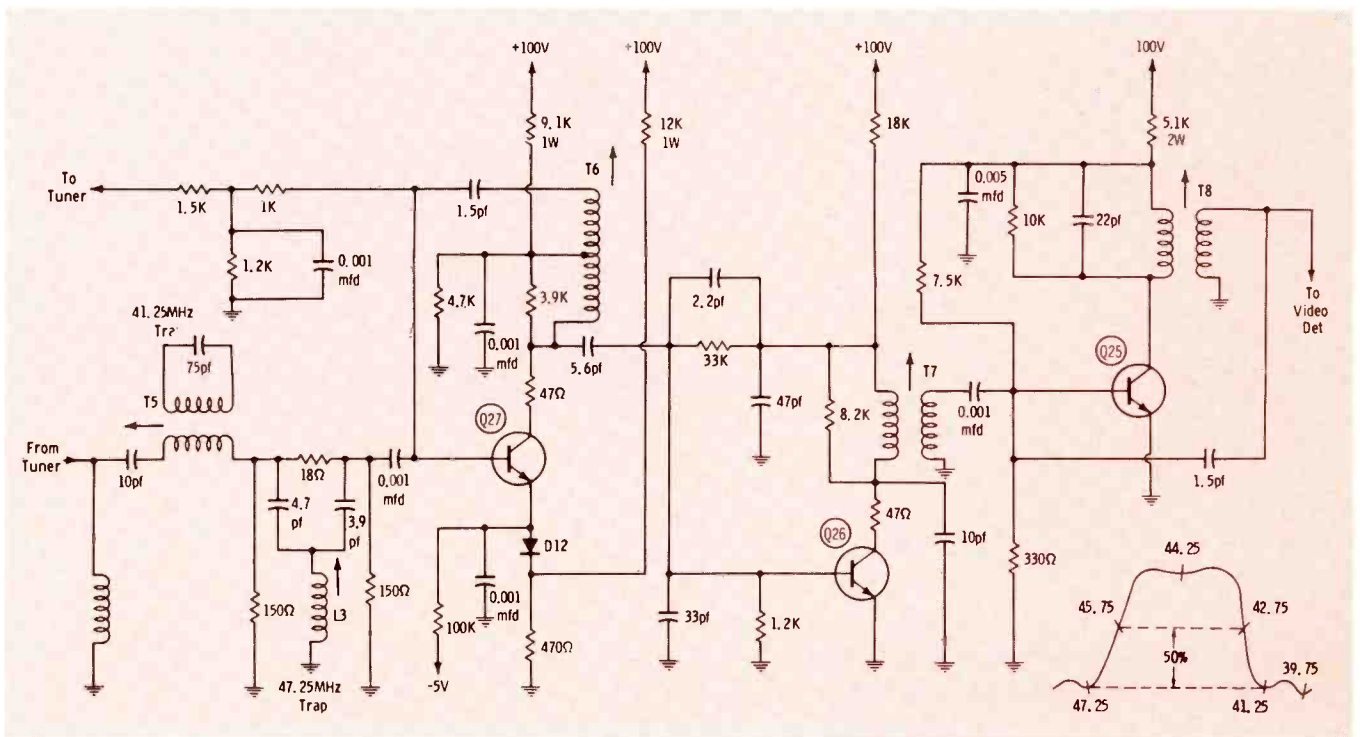

Fig. 1 Typical video IF amplifier circuit.

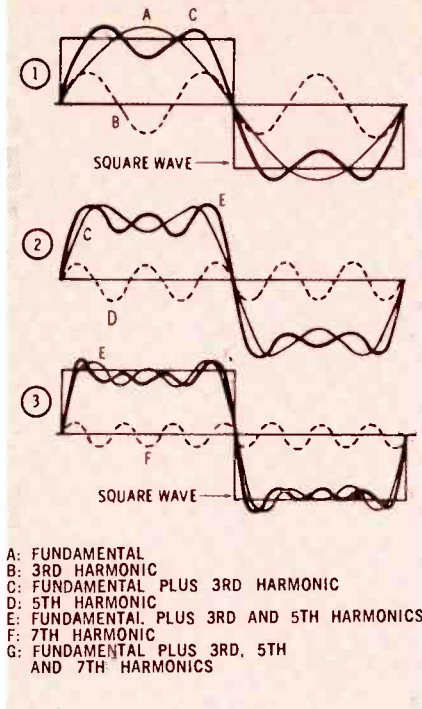

Fig. 2 Composition of a square wave. Note that it is made up of the fundamental signal plus an infinite number of odd harmonics.

flat top of a waveform becomes tilted.

In a typical video IF amplifier, such as that shown in Fig. 1, four tuned circuits are employed. Their resonant frequencies are staggered in a manner that not only provides the required bandwidth, but also provides as linear a phase characteristic as is practical to obtain. Thus, both frequency and phase distortion of the video signals are minimized. When a circuit defect or a misalignment situation causes the bandwidth to be very narrow, the phase characteristic becomes non-linear (curved). In turn, both frequency distortion and phase distortion are produced.

One of the most common causes of excessively narrow bandwidth is defective neutralization, usually caused by open decoupling capacitors. In tube-type receivers, an open screen-bypass capacitor or a gassy tube can cause regeneration. Defective neutralization in a solid-state receiver can be caused by a faulty neutralizing capacitor, or by an incorrect type of replacement transistor. Note in this regard that some types of transistors require neutralization, while others do not. If the former type happens to be substituted for the latter in a receiver

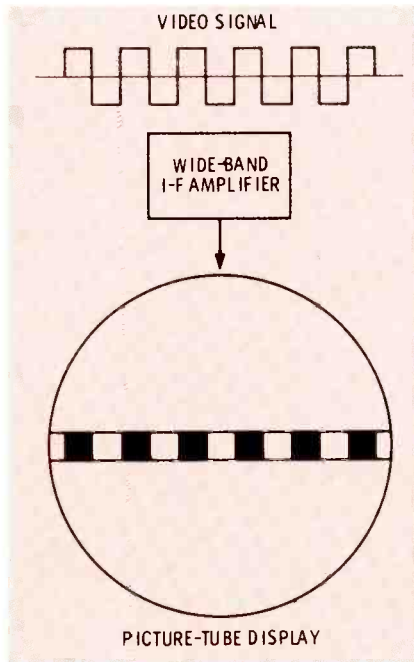

Fig. 3 Square-wave signal produces sharp edge definition when IF amplifier has full bandwidth. Reduction of bandwidth attenuates or eliminates high frequencies, producing poor picture definition—picture becomes fuzzy.

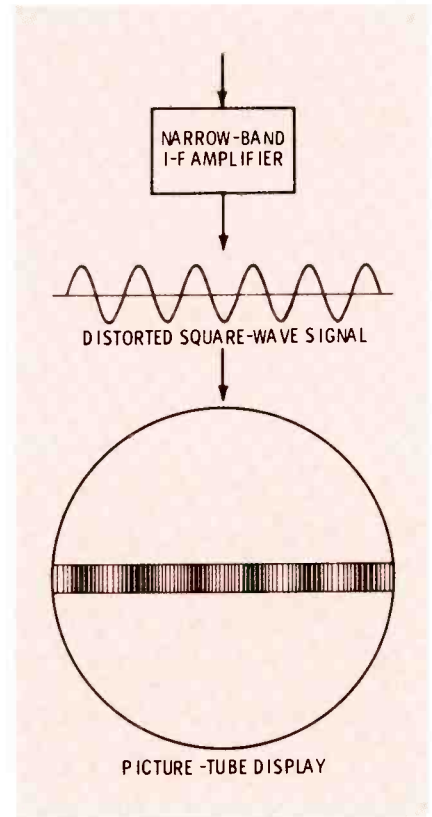
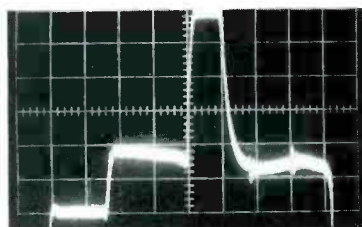
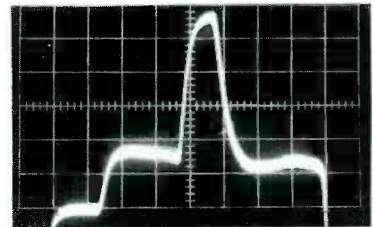

Fig. 4 Loss of edge definition resulting from narrow IF bandwidth.



(A) Normal



(B) Slight Distortion

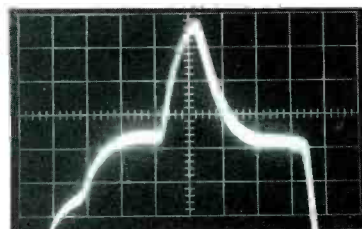

(C) Medium Distortion

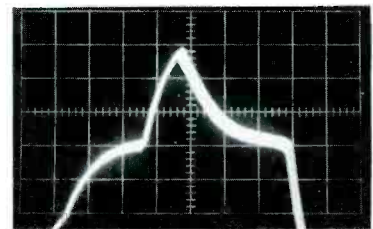

(D) Heavy Distortion

Fig. 5 Progressive "feathering" of the horizontal sync pulse. Picture bending or tearing and loss of sync result when feathering is severe enough.

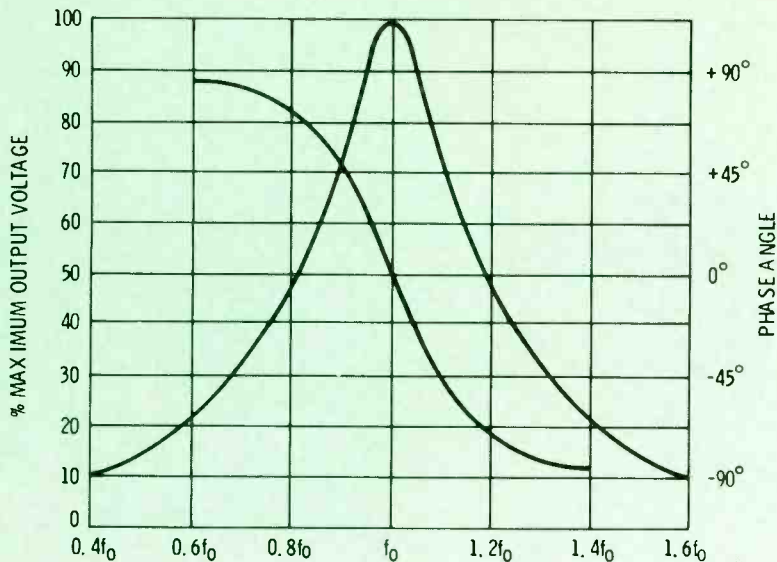

Fig. 6 Frequency and phase response of a tuned coil.

with no IF neutralizing circuits, regeneration or oscillation is an inescapable result.

Regeneration produces a high, sharp peak in the IF response curve which has a frequency corresponding to that of the highest-Q circuit. If one of the stages contributing to the regenerative condition is AGC controlled, the AGC

voltage developed by a strong input signal could reduce the gain of that stage below the point at which regeneration occurs. Because of this, an IF amplifier which is regenerative at comparatively low signal levels often will operate normally at high signal levels.

Common picture trouble symptoms caused by regenerative distur-

tion are shown in Fig. 7. When the regenerative condition is verging on oscillation, herringbone interference (Fig. 7C) appears in the distorted picture. In case the video IF amplifier breaks into oscillation, the picture is "wiped out", and we sometimes see a form of "venetian-blind" pattern. Oscillation in one of the video IF's also is usually accompanied by a high DC voltage output from the picture detector.

Fig. 5 shows that when the IF bandwidth is too narrow, the amplitude of the sync pulse will be reduced, the sync action will be impaired and the distorted picture bends or tears. The extent of sync impairment depends upon the setting of the fine-tuning control, which moves the location of the picture carrier (low video frequencies) up or down the IF response curve. For example, the ringing "blotch" in Fig. 7A moves up or down the vertical wedges as the fine-tuning control is adjusted. In the same manner, IF regeneration can cause separation of sound and picture; when the fine-tuning control is set for best sound reproduction, the picture becomes badly distorted or "wiped out". Conversely, when tuned for optimum picture

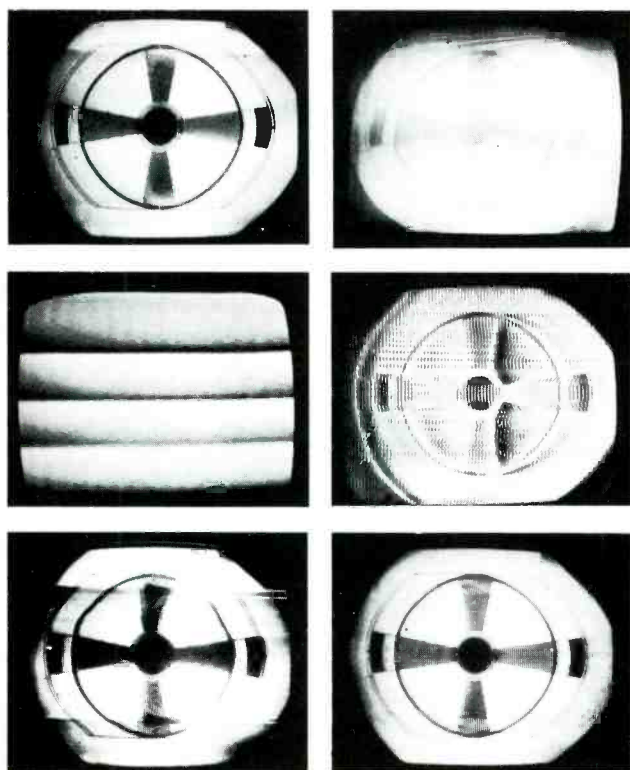

Fig. 7 Six trouble symptoms caused by IF regeneration.

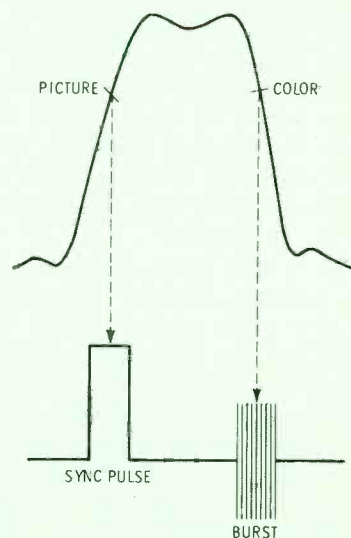
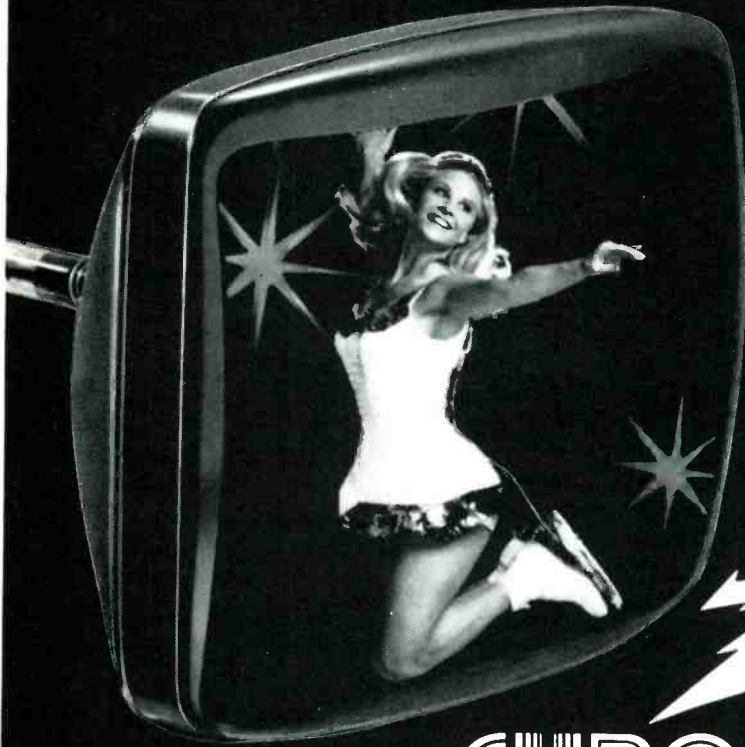

Fig. 8 Sync and color burst components are centered on opposite sides of IF response curve—sync on low-frequency side, burst on high-frequency side.

The replacement picture tube no other color tube can replace!



Simulated TV picture

ZENITH[®]

CHROMACOLOR[®]

Now you can install the revolutionary Chromacolor picture tube in almost any brand of 23" (diag.) color TV. And let your customer see the difference: a new, sharper Chromacolor picture with greater brilliance, contrast and color definition.

Zenith pioneered, developed and patented (U.S. Patent No. 3146368) the Chromacolor picture tube. And only Zenith has Chromacolor.

Chromacolor is an easy sale because people already know of Chromacolor's superiority. (Last year, after the revolutionary new Chromacolor system was

introduced, Zenith giant-screen color TV sets became the No. 1 best-seller!)

Full two-year warranty.

Here's your sales clincher: Chromacolor replacement color tubes are warranted for two full years. Exactly double the warranty period for most other replacement color picture tubes.

Give your customers the best — Chromacolor replacement color tubes. Only your Zenith Distributor has them.

TWO-YEAR WARRANTY

Zenith Radio Corporation warrants the replacement CHROMACOLOR picture tube to be free from defects in material arising from normal usage for two years from date of original consumer purchase. Warranty covers replacement or repair of picture tube, through any authorized Zenith dealer; transportation, labor and service charges are the obligation of the owner.

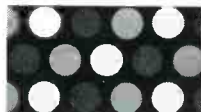

Zenith Chromacolor picture tube pinpoints the color dots on a jet black background and for the first time fully illuminates every dot.

ZENITH[®]

The quality goes in
before the name goes on

Circle 15 on literature card

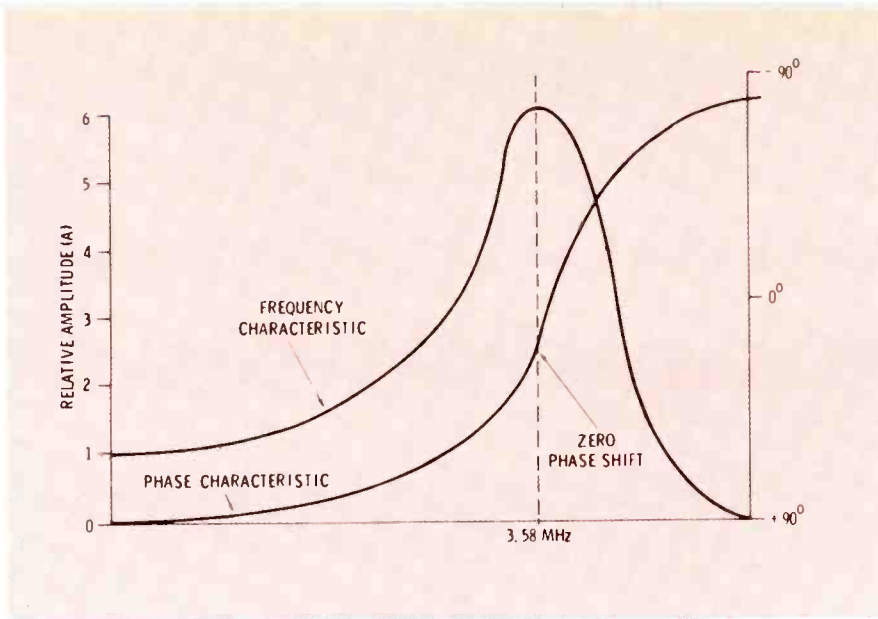

Fig. 9 Frequency and phase characteristics of a bandpass amplifier in a typical color receiver.

quality, the sound becomes distorted or absent.

IF Bandwidth and Chroma Reception

In a color TV receiver, the low-frequency video and the components of the chroma signal normally are centered on opposite sides of the IF response curve, as shown in Fig. 8. When the IF bandwidth is sub-normal, we encounter separation of color and Y signals; in other words,

when the fine-tuning control is set for good contrast of a black-and-white image, the color is eliminated (sometimes along with the sound). On the other hand, when the fine-tuning control is set to obtain color in the image, the contrast is poor. Check the IF alignment when this trouble symptom occurs.

Since the chroma signal normally falls on the high-frequency side of the IF response curve, the bandpass amplifier is aligned with a ris-

ing high-frequency response to compensate for the falling high-frequency response in the IF amplifier. Fig. 9 shows a typical bandpass-amplifier response curve. Like the IF section, the bandpass section has a phase characteristic, as shown in the diagram. The receiver circuitry is designed so that the overall phase characteristic is approximately linear when the tuned circuits are designed for flat overall chroma response. Of course, if the IF strip is misaligned, the overall chroma phase characteristic will be nonlinear, and hues will be distorted accordingly (each hue has a specific phase).

A keyed-rainbow waveform becomes distorted when it is passed through an IF amplifier that has subnormal bandwidth. The photos in Fig. 10 show typical normal and abnormal waveforms. Observe that the effect of narrow IF bandwidth is essentially an integrating action; the rise time of each bar is slowed, and the base interval of the waveform is increased. Poor color "fit" becomes evident at this time. If the IF bandwidth is reduced even further, the distortion becomes more severe, as shown in Fig. 11. Here, the rise and fall times have become so slow that each burst decays only

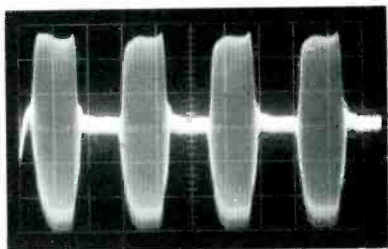

(A) Normal signal.

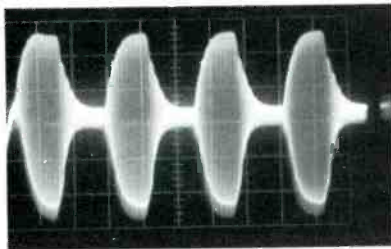

(B) Distortion caused by narrow video IF response.

Fig. 10 Effect of narrow IF bandwidth on keyed-rainbow signal.

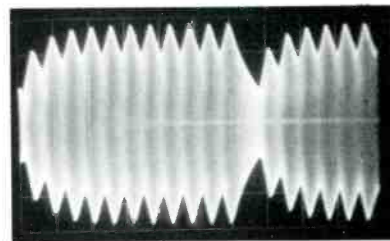

Fig. 11 Waveform distortion produced by extremely narrow-band response of video IF.

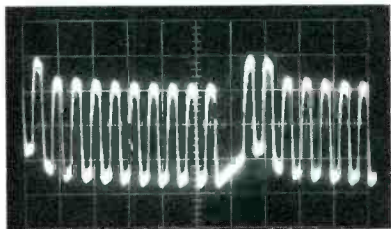
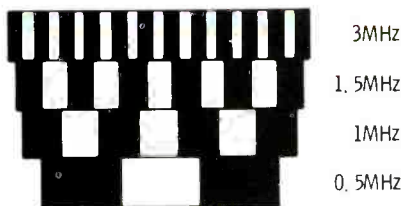
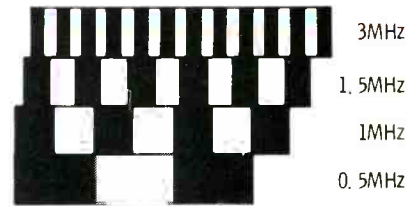

Fig. 12 Distortion of keyed-rainbow signal produced by marginal IF oscillation.



(A) Linear phase action.



(B) Nonlinear phase action.

Fig. 13 Nonlinear phase response causes poor color "fit".

slightly before it is overtaken by the next burst.

When the IF amplifier goes into marginal oscillation, the keyed-rainbow waveform takes on the odd shape illustrated in Fig. 12. In this case, the IF signal is keying the IF amplifier into and out of oscillation on alternate peaks.

The conditions just described produce poor color fit. For example, an actress' lipstick moves off her lips—usually to the right. Shown in Fig. 13 are representative video signals with frequencies of 0.5, 1, 1.5 and 3 MHz. The normal time relations of these signals are as shown in Fig. 13A. When the IF bandwidth is correct and the other tuned circuits are also in proper alignment, the overall phase characteristic is virtually linear, and the normal time relations are maintained. On the other hand, with poor IF bandwidth, the overall phase characteristic becomes nonlinear; the result is abnormal delay of high frequencies, as shown in Fig. 13B. This is the condition that causes poor color fit.

Troubleshooting Sequence

Unless poor IF bandwidth is the result of previous tampering by a do-it-yourselfer, start troubleshooting by making DC voltage measurements. These values are compared with those specified in the receiver service data. In many cases, this procedure will turn up the defective component, such as a leaky capacitor or a faulty transistor. (Beginning technicians tend to overlook schematic notations that indicate the conditions under which the voltage levels and waveforms on the schematic were measured. Failure to take into account these conditions can produce misleading measurements, particularly when the response curves of a color receiver are being analyzed.)

Check alignment last, after component defects have been corrected. Alignment is an exacting science—even when detailed alignment instructions are observed, erroneous adjustments can be made by inexperienced technicians. Before attempting alignment, obtain service data that includes step-by-step procedures, photo and schematic callouts of all alignment points, circuit-connection details, and standard test conditions. ▲

bookreview

RCA Power Circuits Manual: RCA Electronic Components, Harrison, N.J. 07029, Technical Series #SP-51; 448 pages, 5½ inches X 8½ inches, paperback, \$2.00.

This latest revised edition has been expanded and updated to include the most recent available information on the characteristics, capabilities and applications of solid-state power devices. It is intended primarily for circuit and system designers who use solid-state power devices. However, because it is a comprehensive, authoritative reference, it also is useful to others dealing with solid-state power devices, circuits and applications.

Chapter 1, titled "Semiconductor Materials, Junctions and Devices", covers the basics of semiconductor materials, current flow, PNP and NPN structures and types of devices. Chapters 2, 3 and 4 consider silicon resistors, thyristors and silicon power transistors.

The following six chapters cover the wide range of power-circuit applications. Also included is a bibliography, an index and a list of other RCA technical publications.

New Service Literature

TV TECH AID, Edward G. Gorman, Kings Park, L.I., New York 11754; printed monthly; yearly subscription, \$7.95.

A monthly summary of actual color and black-and-white television symptoms, their possible causes and the cure for each. Where needed, a schematic of the circuitry involved is included.

The troubles and cures are grouped according to manufacturers which, in turn, are listed alphabetically. The format of the publication is designed to facilitate filing the troubles and cures according to manufacturer and chassis number—a definite aid to quicker servicing.

SOLID STATE
ONE GUN BOOSTER
FOR COLOR TV



EXTENDS COLOR GUN LIFE **RESTORES RED, BLUE OR GREEN BRILLIANCE**

EASY TO INSTALL
(INSTRUCTIONS ON BACK)

WORKMAN *Electronic* PRODUCTS, INC.
SARASOTA, FLORIDA

WEAK
SERVICE LINE

BEFORE

MODEL NO. WG1

BOOSTED
SERVICE LINE

AFTER

installation of
ONE GUN BOOSTER
Boosts the one weak color needed for a **BALANCED** color picture.

MANUFACTURED BY
WORKMAN *Electronic* PRODUCTS, INC.
SARASOTA, FLORIDA

Circle 16 on literature card

NEED CRYSTALS?

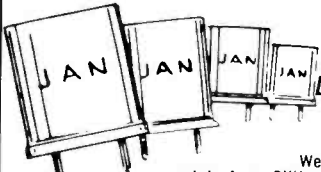

48 HR. Delivery

We can supply crystals from 2KHz to 80MHz in many types of holders.

SPECIALS

Color TV crystal (3579, 545KHz) wire leads	\$1.60; 4 for \$5.00
100KHz freq. std. crystal (HC13/U)	\$4.50
(HC13/U)	\$4.50
1000KHz freq. std. crystal (HC6/U)	\$3.50
Any CB crystal, TR. or REC. except synthesizer crystals	\$2.25
Any amateur band crystal (except 80 & 160 meters)	\$1.50 or in FT-243 holders
4 for \$5.00	
Any marine frequency (HC6/U)	\$2.85
80 meter—FT243 holders	\$2.50

We have in stock over six million crystals which include types CR1A/AR, FT243, FT241, MC7, FT249, HC6/U, HC13/U, HC25/U, HC18/U, etc. Send 10¢ for our 1970 catalog with oscillator circuits, listing thousands of frequencies in stock for immediate delivery. (Add 10¢ per crystal to above prices for shipment 1st class mail, 15¢ each for air mail).

JAN
CRYSTALS

Special Quantity Prices to Jobbers and Dealers
ORDER DIRECT with check or money order to:
2400 E. Crystal Drive
Fort Myers, Florida 33901

Circle 17 on literature card

Sources of noise in TV sound

Techniques for finding difficult, but common, causes. by Wayne Lemons

■ Although removing the buzz from the sound in a TV set might require no more than a tiny adjustment, sometimes that adjustment is

not in the sound circuit at all. Buzz can occur as a result of misalignment and/or component failures in the video IF or tuner. Buzz also can

be coupled to the audio circuits through stray capacitance, or by a ground loop.

A loose vertical or power transformer occasionally sets up an audible vibration that easily can be mistaken for electrically produced buzz. If you suspect this source of buzz, carefully place the end of a screwdriver against or under the transformer; if the transformer is the source, the pitch or volume of the buzz will be decreased or deadened completely. Also, you might be able to feel the vibration through the screwdriver.

Presented here are proven, practical approaches to finding and eliminating noise in TV audio, using only the signal from the TV station as the signal source.

Localizing Buzz

Like solving any other electronic problem, localizing buzz is a matter of eliminating circuits or sections as the possible source, to determine in which we should focus attention.

An easy process of elimination with any audio problem is to turn down the volume. If the buzz decreases at the same rate as the sound, the trouble is probably located prior to the volume-control circuit, which means it could be in the sound IF and detector, or even in the tuner or video IF stages.

If the buzz remains at about the same level when the volume is turned down, the trouble probably is caused by the audio circuitry receiving a spurious signal through capacitance or some other type of coupling, or the trouble could be in the power supply, such as inadequate filtering, which allows the vertical oscillator-amplifier signal to be amplified by the audio section.

The one apparent exception to the preceding method is when the buzz signal is being radiated into the input circuit of the audio amplifier. In this case, turning down the volume will often cause the buzz to disappear or be greatly attenuated when the control is all the way

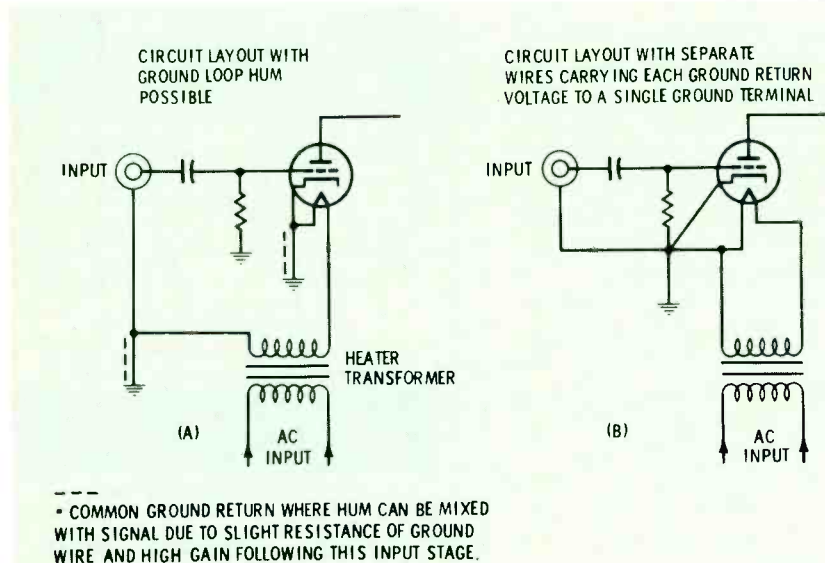

Fig. 1 Simplified circuit diagrams showing (A) a circuit configuration in which a common ground return is used on both audio and power supply current, and (B) a circuit design in which separate ground returns eliminate the mixing of audio and hum voltages.

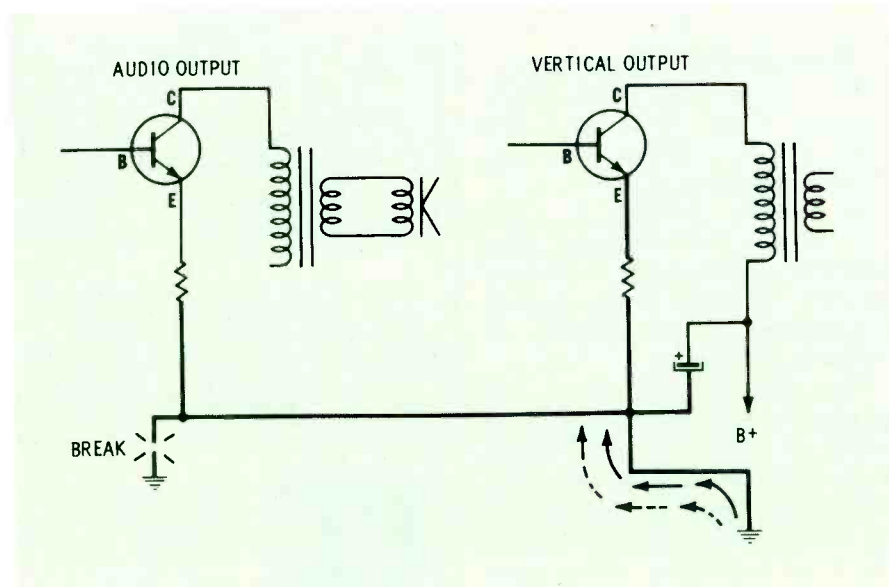

Fig. 2 A broken ground wire or a loose mounting screw can cause a ground-loop problem.

down; this occurs because the variable arm of the volume control is grounded completely in this position, and shorts out the offending signal. The telltale indication here is that the buzz returns at almost full volume just as soon as the volume control is moved from this position.

Buzz in the Audio Amplifiers

If the buzz is traced to the audio amplifiers, it normally reaches there in just one of three ways: It can be radiated directly into the circuit by an audio wire running too close to the vertical circuit or by a vertical lead wire too near the audio circuit. In this case, redressing the wire(s) probably is all that is needed.

The second route is through the power supply, which also is common to the vertical amplifier, video amplifier, and sync circuits. A defective electrolytic can allow enough buzz to be introduced to be annoying, while other filtering in the power supply might suppress the 60- or 120-Hz hum so that only the buzz is noticeable, or the buzz might be strong enough to mask the increase in hum level that otherwise would be apparent.

The third route by which a spurious signal can travel to the audio section is the "ground loop". Ground loops are generally "designed out" by the engineers, but they inadvertently get back in, sometimes because of broken wires, while other times it is introduced by a well-meaning, but uninformed, technician.

A ground loop occurs any time a ground wire carries both the audio signal and another alternating current signal as well. Ground loops can be the source of both hum and buzz, depending on which kind of signal is coupled into the loop. Fig. 1 shows one way this can happen. The circuit in Fig. 1A is designed so that both audio and relatively heavy power supply current flow to ground through a common piece of

wire; this is a ground loop. Hum occurs because no length of wire has absolutely zero resistance, and, consequently, there is always a voltage

drop across it—the heavier the current, the more voltage dropped. Even though the hum voltage in this circuit might only be a millivolt or

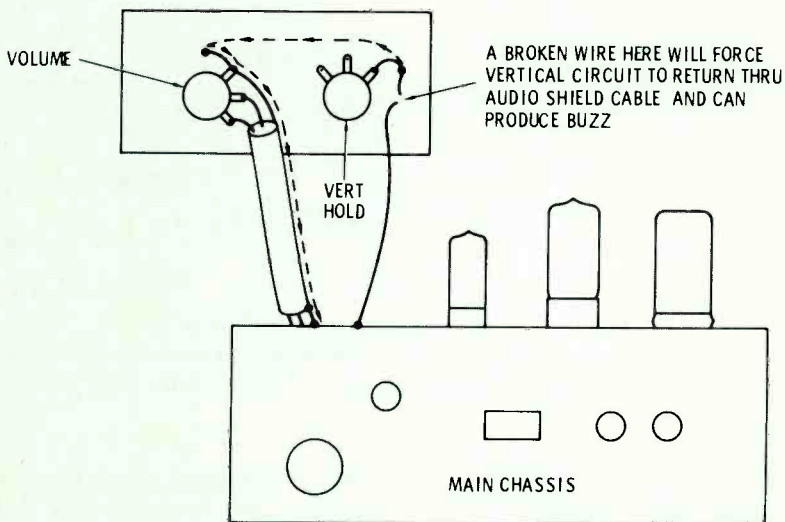

Fig. 3 One example of how a ground loop can occur when a separate control panel is used.

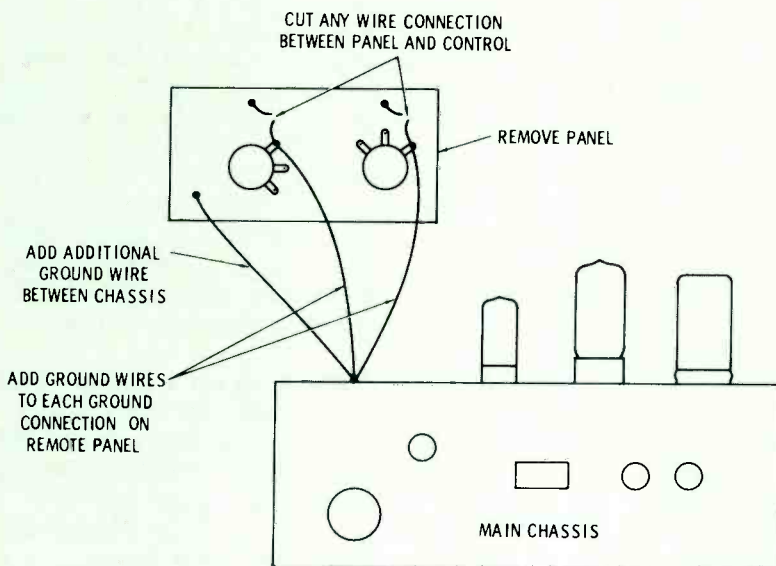

Fig. 4 How you can be sure of avoiding ground loops when a separate control panel or chassis is used.

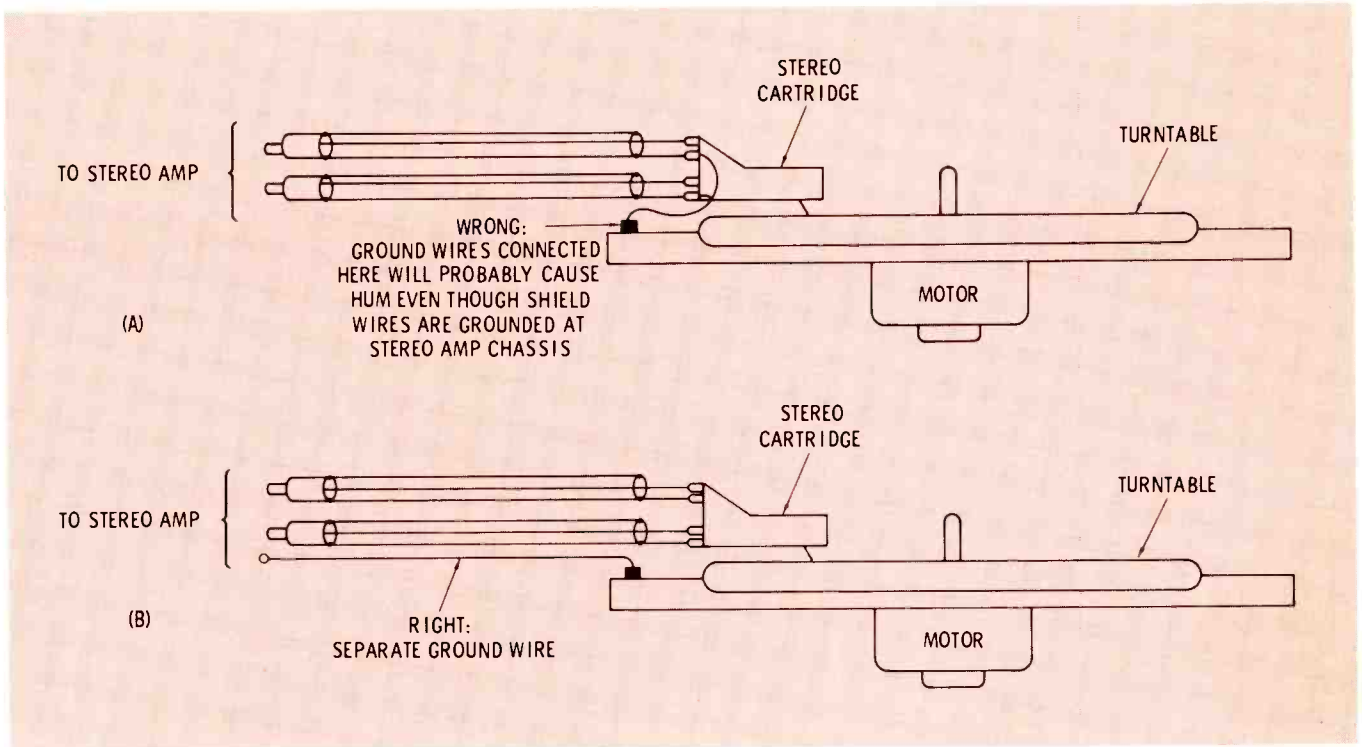

Fig. 5 How ground loops can be prevented in stereo phonograph systems.
(A) Improper ground connections **(B)** Proper ground connection

so, when it is mixed with the low-level audio and amplified by the audio amplifiers, an annoying, audible hum will be heard in the speaker.

You will not often encounter an original design problem (though it has happened), but a broken wire, broken printed circuit, or a ground added where it shouldn't be can cause a ground loop problem that defies diagnosis.

Fig. 2 shows how a broken ground lead in a transistor TV set might cause buzz. The broken ground lead forces the audio to return through the same ground as the one for the vertical circuit. This is how a broken or loose ground can cause buzz. In transistor TV, it normally can be corrected by simply tightening down the screws holding the printed-circuit board to the metal chassis.

One of the most difficult ground loops to find is produced when someone inadvertently "re-designs" the circuit. Usually, both ends of a shielded audio cable should be grounded, but sometimes only one end should be grounded. If the latter is the case, adding a ground at the other end of the cable might

provide a shorter, or at least an alternate, path through which vertical pulses or power supply current can pass, thereby considerably increasing the buzz level. Suspect an added ground when the source of buzz doesn't appear to be any of the more conventional causes.

Another ground loop possibility occurs when a remote chassis or panel is used. A common wire, for example, carrying both audio return and other pulse or alternating current signals can be a common coupling impedance, which increases the buzz or hum level. Depending upon the circuit design, a wire might break during servicing and produce no other effect except to increase the buzz level. Fig. 3 shows one example of this.

Checking for a Ground Loop

A good test for ground-loop trouble is to use a short, heavy jumper to temporarily connect each audio ground point to a convenient point on the metal chassis. Or if a remote chassis is being used, temporarily connect a heavy jumper between it and the main chassis. Even a slight reduction in hum indicates that somewhere in the circuitry

there is a common coupling impedance feeding hum or buzz into the audio circuits. Carefully check for broken leads, broken printed circuits, mounting screws not making a secure ground connection from the chassis to the printed board, and other similar physical defects in wiring or printed circuits.

If a remote chassis is involved, be sure to remove all possible ground loops by connecting separate ground wires between each remote ground terminal and the main chassis; then run an entirely separate ground wire between the two chassis. Fig. 4 illustrates these procedures.

Although we primarily are discussing TV sound, the above method is the only effective remedy for ground loops that cause hum in stereo phonograph systems—there must be a separate ground wire return to each source and a third wire to ground between the amplifier and motor/turntable chassis, as shown in Fig. 5.

Buzz or Noise Prior to Volume Control

If the volume of the buzz or noise you hear in the speaker increases and decreases as the volume

Important New SAMS Books

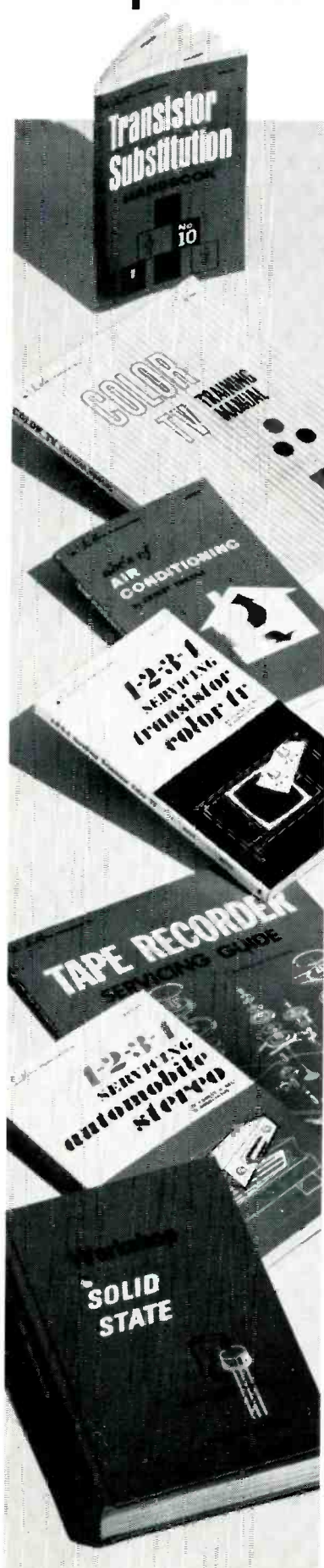

New 10th Edition of the Sams

Transistor Substitution Handbook

by the HOWARD W. SAMS ENGINEERING STAFF. Fully updated to include tens of thousands of substitutions. Covers all manufacturers and gives proper substitutions for all types of bipolar transistors: U.S. and foreign, home-entertainment and industrial. Computer-compiled for accuracy. Also includes manufacturers' recommendations for general-replacement transistor substitutions. Order 20773 only.....\$1.95

Color-TV Training Manual, 3rd Edition

by the HOWARD W. SAMS ENGINEERING STAFF. The completely revised third edition of this famous training guide covers all the latest developments in the field. Written for the technician preparing to service color TV receivers. Describes the science of color, requirements and make-up of the color signal, latest color circuits, and practical setup and servicing procedures. Includes full-color picture tube photos. Order 20736, only...\$6.95

ABC's of Air Conditioning

by ERNEST TRICOMI. This book presents a non-technical explanation of the laws of physics which relate to air conditioning and shows how these laws are applied practically in the design and manufacture of all types of air conditioning units and their components. Covers components common to all systems, electrical systems, estimating capacity and installation methods, and air conditioning repairs. Order 20725, only.....\$2.95

1-2-3-4 Servicing Transistor Color TV

by FOREST H. BELT. The "1-2-3-4 Method" is a simple, logical, step-by-step process which helps do the service job the right way and the easy way. In this book, the fundamentals of transistor color TV are covered, followed by a detailed explanation of how to apply the method for quick troubleshooting and easy repairs. Supported by a wealth of illustrations, charts, and block and schematic diagrams to make understanding easy. Order 20777, only.....\$4.95

Tape Recorder Servicing Guide

by ROBERT G. MIDDLETON. Thoroughly explains the principles and characteristics of magnetic recorder circuitry, describing the various components and systems. Provides comprehensive instructions on preventative maintenance, adjustments and minor repairs, and solving tape transport, recording, and reproduction troubles. Order 20748, only.....\$3.95

1-2-3-4 Servicing Automobile Stereo

by FOREST H. BELT. This book first applies the ingenious "1-2-3-4" repair method to both mechanical and electrical equipment and then proceeds to cover the electronic and mechanical principles of automobile stereo, fm multiplex and tape cartridge systems. Finally, the book shows how to apply the method to auto stereo systems. Includes many schematics, charts and illustrations. Order 20737, only.....\$3.95

Workshop in Solid State

by HAROLD E. ENNES. Presents the technology of transistor operation in terms familiar to those educated in tube technology. Provides an orientation in solid state principles, and a detailed analysis of the diode; covers transistor parameters, linear switching and pulse circuits, a wide variety of practical design problems and applications and basic testing and servicing techniques. Order 20735, only.....\$9.95

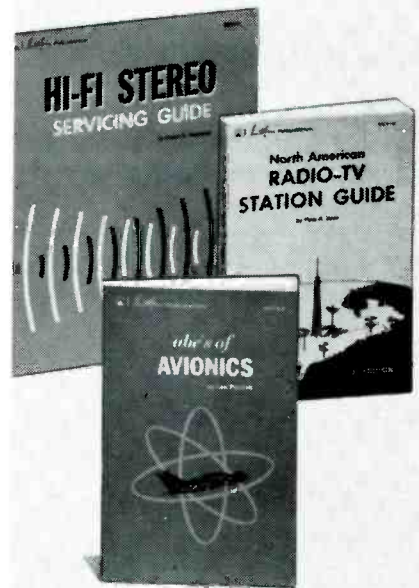

Hi-Fi Stereo Servicing Guide

by ROBERT G. MIDDLETON. This book is a complete guide to effective hi-fi and stereo servicing. The author provides the basis for a full understanding of hi-fi tuner and amplifier circuitry and procedures for proper servicing of this type of equipment. The proper use of audio test and measurement equipment and the basic principles of acoustics are also given. Covers all components of the system (except record players and tape recorders). Order 20785, only.....\$3.95

ABC's of Avionics

by LEX PARRISH. This book provides a basic understanding of avionics—the electronic equipment used to insure the safety of crew and passengers. The type of equipment and the techniques employed in private aircraft operations are featured. The requirements for basic communications, navigation aids, instrument flight aids, weather guidance equipment, and special flight control safety devices are discussed. Explains the terminology of avionics. Order 20764, only.....\$3.50

North American Radio-TV Station Guide, 6th Edition

by VANE A. JONES. Lists all the radio and television stations in the United States, Canada, Mexico, and the West Indies. Includes a-m, fm, and television stations presently in operation, as well as those that are about to start operating, or are temporarily off the air. Separate listings arranged by geographical location, frequency (or channel), and call letters make this guide the most useful one available. Also includes data on power and antenna height. Order 20779, only.....\$2.95

HOWARD W. SAMS & CO., INC.

Order from your Electronic Parts Distributor, or mail to Howard W. Sams & Co., Inc., Dept. ES-080 4300 W. 62nd St., Indianapolis, Ind. 46268

Send books checked at right. \$_____ enclosed
 Send FREE 1970 Sams Book Catalog

Name _____
 Address _____
 City _____ State _____ Zip _____

- | | |
|--------------------------------|--------------------------------|
| <input type="checkbox"/> 20773 | <input type="checkbox"/> 20737 |
| <input type="checkbox"/> 20736 | <input type="checkbox"/> 20735 |
| <input type="checkbox"/> 20725 | <input type="checkbox"/> 20785 |
| <input type="checkbox"/> 20777 | <input type="checkbox"/> 20764 |
| <input type="checkbox"/> 20748 | <input type="checkbox"/> 20779 |

Circle 18 on literature card

control is turned up and down, the source of the noise probably is in a circuit prior to the volume control.

Nearly all present-day, tube-equipped chassis use some form of quadrature detector, because of its simplicity.

Fig. 6 shows the Zenith-type detector, the first of the quads. It uses a "buzz" control in the cathode circuit.

Fig. 7 shows the other type employed in the chassis produced by most other manufacturers. It has a

fixed cathode resistor, but uses an additional resistor and capacitor connected in series with the quad coil. This type is sometimes called an "oscillating" detector since it oscillates weakly at low signal input, and thereby reduces noise by producing an "RF carrier effect" when station signals are weak.

Both of these detectors should be adjusted carefully for maximum buzz rejection, and both should be adjusted with a "down in the noise", or low-level, broadcasted signal input. Signal strength can be reduced

best by using a variable H pad in the antenna line; however, simply removing the antenna leads (both, not just one) and holding the lead near the antenna terminals works well in most cases. After the adjustment for minimum buzz has been completed, the antenna should be reconnected and the set checked on all received channels.

One thing that must not be overlooked when attempting to adjust a quad detector is that the input sound IF coil also must be correctly adjusted. If adjusting the quad coil (and buzz control when used) does not reduce the buzz to an acceptable level, try adjusting the sound IF input coil while a very weak signal is being received. (Remember, it is the IF input coil with which the quad coil must be in quadrature.) Also carefully adjust any other sound IF coils and the sound take-off coil for best sound.

Video IF Problems

The intercarrier sound system is used in all TV receivers marketed today in the U.S. In this system, the video and sound carriers are beat together at the video detector to produce a 4.5-MHz audio carrier.

But why is the resultant 4.5-MHz signal an audio signal? Why doesn't it also have the characteristics of the video signal? The answer is that it would have, except that when two signals are heterodyned, or mixed, the resultant signal will contain only the characteristics of the weaker of the two signals if the weaker signal is **considerably** weaker. Because of this, the sound signal must be kept at a low level during its journey through the video IF; otherwise, sync pulses and even video hash would be so strong in the 4.5-MHz sound signal that no amount of "detecting" or limiting in the sound IF and detector could remove the resultant noise and buzz. In practical terms, this means the "high-low" relationship between video and sound carriers in the video IF stage is essential.

If the AGC system of a receiver is not functioning properly, one of the first things that might occur is buzz in the sound. Buzz can sometimes be cured by adjustment of the AGC control, but if the AGC adjustment does not eliminate the buzz

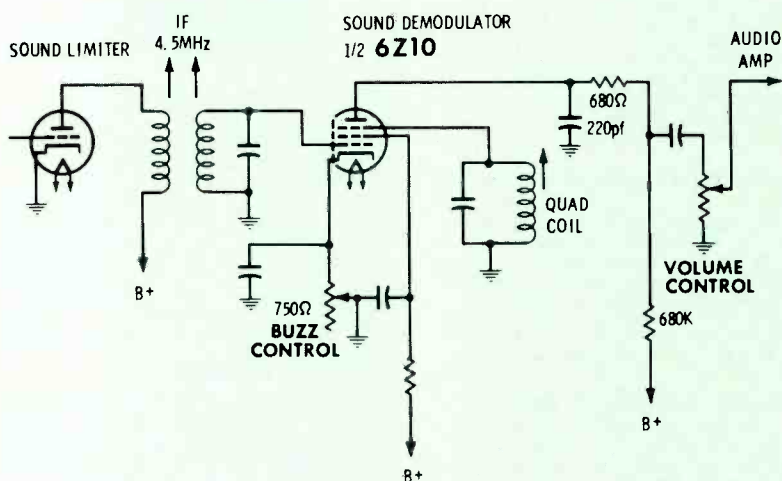

Fig. 6 Zenith-type quad detector has a buzz control in the cathode.

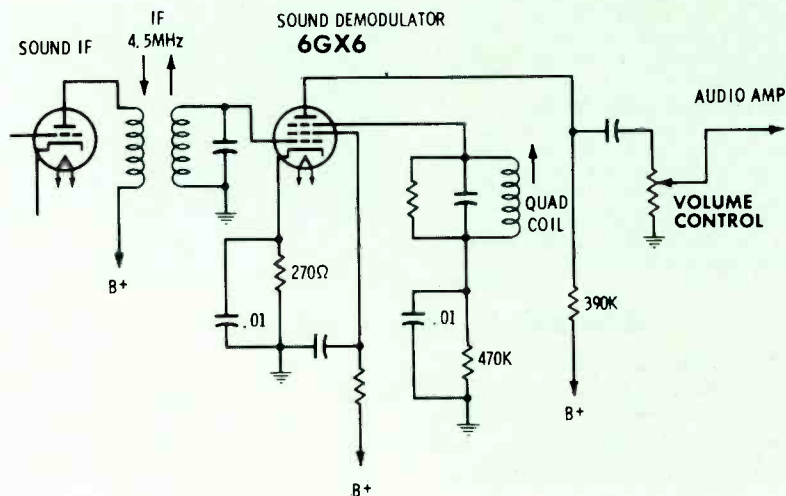

Fig. 7 An "oscillating" quad detector tends to oscillate with low signal inputs, which produces an "RF carrier" quieting effect.

without washing out the picture, the real problem is probably slight misalignment of the receiver video IF's and related sound traps. To correct for this, you usually only need to "tweak" the 41.25-MHz sound trap for minimum buzz. In drastic cases involving b-w receivers, you might have to "tweak" a video IF adjustment while watching the picture to make sure there is no unsatisfactory change and at the same time listening for better sound. (Do **not** attempt this procedure with color TV chassis—the position of the color subcarrier and sidebands on the response curve is too critical to permit adjustment while using only picture quality as a reference.)

Oscillation or Mismatch

Either oscillation or mismatch (or both) can cause incorrect "tilt" of the video IF amplifier response curve, and as a result the sound carrier could be shifted too high on the response curve.

To prevent this, be sure the right tubes are installed in the video IF and the tuner. If a new transistor has been installed, the IF might have to be retuned slightly to reduce the tendency for the circuit to oscillate, or to decrease the sound carrier to its proper level. Be sure all shields are in place and all grounding screws are tight.

A mismatch can be caused by an open shield on the tuner-IF cable or an open antenna coil in the tuner. To check for an open shield, move your hand along the cable; if the shield is open, the picture and sound will change as you move your hand along the cable. Running your hand along a properly shielded lead should have little effect on the picture, except during reception of UHF signals—the lead-line match is seldom anywhere near perfect on UHF, but because of the broad-band nature of the tuner, the mismatch here seldom causes "buzzy" sound. Check for an open antenna coil with an ohmmeter, if possible, or by inspection.

VHF tuners with triode RF amplifier tubes can oscillate if not properly neutralized, and this can cause buzz in the sound. To neutralize it (or see if it will neutralize), remove B+ from the plate of the tube; connect an antenna to the set and tune to a strong high-band sta-

tion; adjust the neutralizing control for MINIMUM picture and sound.

Other Common Causes

In this article we have **not** covered the classic causes of audio noise—such as open electrolytics in the power supply lines; defective speakers, tubes or transistors; noisy resistors; etc.

We also have not covered noise problems which can be caused by component failures which would produce the same effects as misadjustments, mismatch or oscillations.

Special Caution

You should make no major "tweaks" of adjustment without first carefully making sure that the circuits are otherwise functioning properly. No large adjustments should be made without benefit of alignment equipment, especially in color sets. In b-w sets, small adjustments for the purpose of improving sound (while watching to see that picture is not degraded) are permissible using just the station signal. ▲



Don't shoot till you see the tenths of a volt.

The sure way to troubleshoot solid state TV is with a scope that measures DC.

Take Leader's five-inch LBO-53B:

It gives you a drift-free DC input, so you can see those tenths of a volt. It gives you a bandwidth to 10 MHz. And it gives you a sensitivity of 10 mv/cm or better.

Now for the shocker. You can have a Leader LBO-53B for just \$229, about half the price of any other scope with the same capabilities.

Since the proof is in the seeing, we direct you to your Leader distributor. Ask to see our color bar generators too; you haven't seen the finest until you've seen Leader's.

Seeing is believing.

Leader Instruments

37-27 27th Street, Long Island City, N. Y. 11101, (212) 729-7411

Circle 19 on literature card

Aquadag Arcing

The flyback transformer in a General Electric KD color TV chassis burned out. After installing a new flyback, retracking the gray scale with the screen color adjustments and refocusing, I discovered that, after the set operated for several minutes, intermittent arcing developed at the ground straps for the aquadag coating on the picture tube. The aquadag was missing from around both grounding straps. I applied fresh aquadag to this area, but the arcing continued.

I can stop the arcing by increasing the CRT bias, which produces poor focus and loads the flyback, or by removing the plate lead from the shunt regulator, which causes the high voltage to increase to 30 kv. I have replaced the shunt regulator and all other high-voltage tubes, and have checked all capacitors and resistors in the shunt regulator circuit. No arcing can be detected in or near the regulator tube.

What can be causing this arcing?

William Pokorny
Clarendon Hills, Illinois

A sudden change in high voltage will cause arcing from aquadag to ground in any picture tube. The two schematics shown here should help you understand why this is true. Capacitance is formed by the inner

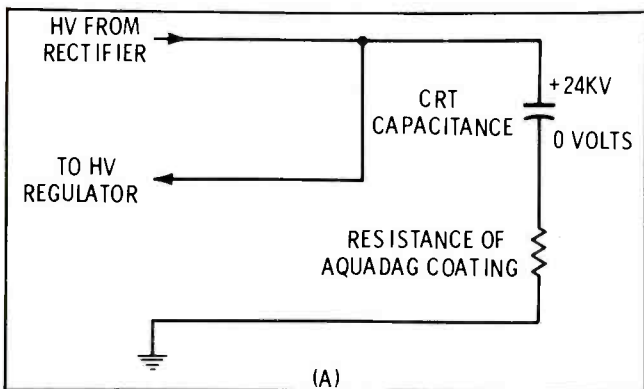

and outer coating on the glass of the picture tube. During normal operation this capacitance charges up to the value of the high voltage and acts as a storage device to furnish current to the load (picture tube anode) between horizontal pulses of DC.

One of the chief ingredients of aquadag is carbon, and a definite resistance can be measured with an ohmmeter between points on the aquadag coating. Normal current through the aquadag is small, so the exact resistance is not important. This is the circuit in (A).

The schematic in (B) shows that an arc in the high-voltage rectifier or regulator tube would virtually ground the 24 kv of high voltage for the duration of the arc. For a very short period of time, the CRT capacitance is still fully charged, but the anode of the picture tube (it is connected to the inside aquadag) is now grounded. The other plate of the capacitor (outside aquadag), at this point in time,

has -24 kv on it. This same -24 kv is between aquadag and ground. Arcs will jump to the ground straps and also to other grounded metallic parts that are near. After the arcs from aquadag to ground and

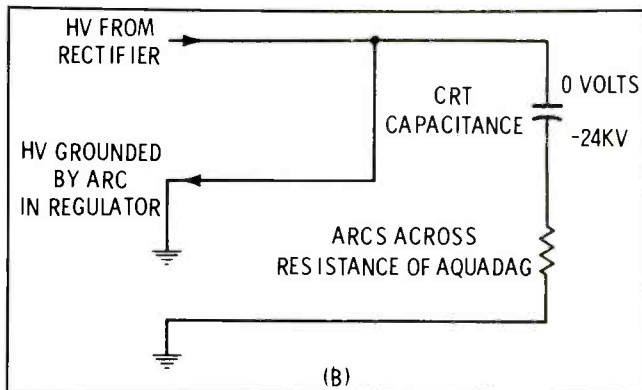

high voltage to ground (or B+) cease, the high voltage returns, charges the CRT capacitance and operation is normal until the next arc.

Where could such a large and instantaneous decrease in high voltage occur? Either by an arc or an intermittent open in the horizontal-output tube, damper, high-voltage transformer, high-voltage rectifier or socket, or high-voltage regulator tube. In this specific case, the regulator tube or the regulator circuit is the prime suspect, because the arcing stops when the plate cap of the regulator tube is removed, even though this increases the high voltage.

Poor Convergence

An Admiral 2G11 color chassis (PHOTOFACT 825-1) has poor convergence. The blue horizontal lines are misconverged for seven inches from the right side, and the red vertical lines on the right side are displaced to the right of both the blue and green. The p-p voltages on the convergence board (list on enclosed page) are within a few volts of the ones listed in PHOTOFACT, and all waveforms also conform. All parts on the convergence board have been checked and are okay.

Arthur Dreifort
Los Angeles, Calif.

You have done a good job testing some of the circuits, especially the p-p readings on the convergence board. However, the help we might have obtained from an analysis of the crosshatch pattern before any adjustments were made has been lost.

Following are a sequence of tests and some tips on convergence, along with comments about the particular trouble symptoms you have encountered:

- Tune in a normal, sharp crosshatch pattern. Center converge, but do NOT adjust anything else, just yet. Notice (perhaps write down) the condition of the convergence at 4 points on the screen—top center, bottom center, left center and right center. Choose a junction of the lines about 2 inches or so from the top or bottom and 3 to 4 inches from the sides of the CRT.

- Try to adjust the convergence using a good, tested, logical system. If any controls are erratic, they might be open or have bad soldering joints. Notice any adjustments that do not accomplish enough correction. Don't stop now, but finish the setup. When you ad-

just the horizontal coils, does one of them fail to move the crosshatch lines? Is the core cracked? If the coil is colder than the other two it might be open; if warmer, it might have shorted turns.

- If the horizontal convergence doesn't function normally on any of the three colors, as seems to be the case with the Admiral, repairs must be made before proceeding.

- Carefully test diodes X6A, X6B and X6C, or, better yet, replace them and try to converge again. It is not accurate to check the diodes in-circuit, because of the low-resistance shunting paths. Note: these diodes are in the part of the circuit that affects the convergence on the left side; however, they also affect center convergence and convergence on the right side. It is possible for the crosshatch analysis to show worse convergence on the right side and the cause still be one or more of these diodes.

- Other essential parts of the convergence circuits (but often overlooked in troubleshooting) are the dynamic convergence coils around the neck of the picture tube. An open circuit in one of these coils can be very misleading, since we might expect no results at all from one adjustment in that event. Red and green are adjusted together, and if the red dynamic coil is open, the green coil still functions, so the red-green lines do move on the screen. It is highly advisable to check all three vertical (95 ohms) and three horizontal (8 ohms) windings with an ohmmeter. An in-circuit test is satisfactory because, even though the setting of the various controls will change the read-

ings up to 20 or 30 percent, an open coil will create even more of a resistance change.

- Positioning of the convergence pole pieces over the CRT guns is critical. If the convergence yoke assembly is too far forward, backward, or rotated slightly, the adjustments cannot be forced to full correction. Also, the ends of the iron cores of the pole pieces must be against the glass of the picture tube neck. If any core is snagged and not seated properly, the convergence will be ineffective.

- Other tips: Red and green should be adjusted together, preferably with blue switched off. Afterward, the blue is adjusted to match the yellow (red plus green), if possible. But the red-green convergence is the more important one and should *not* be compromised to help the blue.

- If the blue raster seems to be wider, or said another way, if the blue vertical lines on the right side of the screen are to the right of the yellow, and those on the left side of the screen are to the left of yellow, the deflection yoke is drooping in front or the whole yoke is too low on the neck of the CRT. Either adjust the yoke to a higher position or ignore the blue misconvergence (it is the easiest color to ignore), but do *NOT* try to bring the red and green lines over to the blue. This advice is based on human eye characteristics, not electronics.

(Anyone who would like to learn more about color TV setup is advised to read the chapter starting with page 51 in "Color TV Servicing Made Easy—Vol. 2," Howard W. Sams Catalog No. 20523.) ▲

SAVE \$478
WHEN YOU
BUY THIS
6-PACK!

AVAILABLE FROM YOUR
CHEMTRONICS DISTRIBUTOR



CHEMTRONICS I N C 1260 RALPH AVENUE
BROOKLYN, N. Y. 11236

Circle 20 on literature card

MOBILE RADIO SERVICING

Part 3

Proof-of-performance tests ...

by Leo G. Sands

Responsibility

As far as the mobile radio user is concerned, the proof of the pudding is in the "talking". But, the **Federal Communications Commission (FCC)** is concerned with **proof of performance in accordance with its technical standards.**

The licensee of a mobile radio system is legally responsible to the FCC for compliance with FCC Rules and Regulations. And, the service technician is morally responsible to his customers, the licensees, who must rely upon him to insure that their equipment performs in accordance with FCC technical standards.

It was once required by the FCC that transmitter frequencies be measured at regular intervals (usually at least once every six months, or more frequently). The licensee was required to state in his station license application how often transmitter frequencies would be measured, and with what instruments, or by what qualified service organization.

This is no longer required. But, a forfeiture can be levied by the FCC against a station licensee for off-frequency operation and other rule violations.

Type Acceptance

All transmitters used in all of

the land mobile radio services, except in the Class C and Class D Citizens Radio Service, must be FCC "type-accepted" under the applicable part of the rules (Part 89, 91, 93 or 95). It generally can be assumed that all **new** models of reputable make have been FCC type-accepted. If there is any doubt, the equipment should be looked up, by make and model number, in part C of the rules, which lists equipment acceptable for FCC licensing in the non-broadcast services. Or ask the manufacturer for the FCC type-acceptance number.

Thousands of **used** mobile units and base stations in operation are **not** currently type-accepted. Many dealers buy and resell traded-in or "junked" equipment from surplus distributors. Most of these sets are wide-band FM types (± 15 KHz) which have been modified by the surplus distributor or dealer for narrow-band (± 5 KHz) operation. The dealer often sells these sets without knowing that the user will be violating FCC rules, because merely modifying them does not make them acceptable for FCC licensing.

However, the surplus distributor or dealer can apply for type-acceptance by making the necessary measurements and filing an application

Table 1

FCC TECHNICAL STANDARDS

FREQUENCY STABILITY*	TOLERANCE
Below 25 MHz	0.01%
25-50 MHz	0.002%
150-174 MHz	0.0005%
450-470 MHz (base)	0.00025%
450-470 MHz (mobile)	0.0005%
EMISSION LIMITATIONS**	TOLERANCE
25-50 MHz	± 5 KHz FM
27.23-27.28 MHz	AM or SSB
150-174 MHz	(8 KHz max)
450-470 MHz	± 5 KHz FM
	± 5 KHz FM

*Looser tolerances allowed for transmitters under 3 watts.

**AM may be authorized instead of FM.

Table 2

FCC RULES AND REGULATIONS

VOLUME II	\$2.00
Part 2, Frequency Allocation, Type Acceptance	
Part 15, Unlicensed Transmitters	
VOLUME IV	\$2.00
Part 81, Maritime Services (land)	
Part 83, Maritime Services (ships)	
VOLUME V	\$2.50
Part 89, Public Safety	
Part 91, Industrial	
Part 93, Land Transportation	
VOLUME VI	\$1.25
Part 95, Citizens	
Part 97, Amateur	

Table 3

EQUIPMENT FOR PROOF-OF-PERFORMANCE TESTS

Instrument	Applications	Comments
Frequency meter (crystal controlled)	Transmitter frequency measurements. RF signal generator (fixed freq.)	Measures only those frequencies for which crystals are provided. Easy to use. Also measures modulation level.
Frequency meter (tunable)	Transmitter frequency measurement. RF signal generator.	Flexible. Human errors possible.
Frequency synthesizer	Transmitter frequency measurement. RF signal generator.	Expensive.
Electronic Counter	Transmitter frequency measurement.	Very accurate. Highly recommended. Easy to use.
Frequency deviation meter	Transmitter modulation level.	Often combined with crystal-type frequency meter.
FM deviation oscilloscope	Transmitter modulation level. Modulation quality.	Highly recommended.
VHF-UHF/FM signal generator (tunable)	Receiver performance measurements (at operating and spurious frequencies).	Must be laboratory grade.
LF-MF-HF/AM signal generator (tunable)	IF amplifier and discriminator symmetry tests.	Harmonics can be used for VHF checks.
LF-MF signal generator (crystal controlled)	IF amplifier and discriminator symmetry tests. Receiver frequency accuracy tests.	Available factory-made or can be home-made.
AF signal generator (tunable)	Frequency response measurements.	Essential.
AF signal generator (1000-Hz fixed tuned)	FM deviation tests.	Time saver.
Monitor receiver (tunable 30-50 MHz)	Transmitter modulation monitoring.	Inexpensive, handy.
Monitor receiver (tunable 150-174 MHz)	Transmitter modulation monitoring.	Inexpensive, handy.
Frequency converter (tunable 450-470 MHz)	Transmitter modulation monitoring.	Use with 30-50 MHz monitor receiver.
TV receiver (VHF/UHF)	TVI checks.	Essential.
Communications receiver (tunable 0.54-30 MHz)	Spurious emission checks. Calibrator.	Provides flexibility.
FM receiver (tunable 88-108 MHz)	Checking 30-50 MHz band transmitters for harmonics.	Optional.
VTVM or FET-VM (DC, AC, RF)	Level measurements.	Essential.
Oscilloscope (DC to 4.5 MHz)	Waveform observation	Optional, but recommended.
RF wattmeter (50-ohm)	Transmitter RF output measurements.	Essential.
SWR meter	Transmitter RF output measurements.	Use with 50-ohm dummy load.
Dummy antenna load (50-ohm)	Protect transmitter.	Essential.
Spectrum analyzer	Observation of transmitter emissions.	Optional, expensive.

for type-acceptance, as spelled out in Part 2 of the FCC Rules and Regulations. This can be a costly, and is a time-consuming, chore.

Also, many dealers sell factory-made linear RF power amplifiers for use with low-power AM mobile units and base stations (business band), assuming that their use is legal. Even when the power rating of the amplifier is within legal limits, and the amplifier has been type accepted, it can be operated legally only when used with the transmitter specified in the type-acceptance document. The FCC advises that type-acceptance of a booster amplifier is applicable only when used with a specific make and model transmitter.

When a technician is called upon to service mobile radio equipment which he knows (or believes) is not type accepted, he should make the customer aware of the fact. Otherwise, the technician is an accessory to the violation. The technician can, if he has the capabilities and facilities, make the required measurements and apply for FCC type-acceptance, if the measurements indicate that the equipment qualifies.

FCC Technical Standards

FCC technical standards are not the same for all frequency bands and differ in some respects with transmitter power, as Table 1 indicates. These standards are subject to change. Therefore, every shop should have a set of the applicable parts of FCC Rules and Regulations (listed in Table 2), and should subscribe to the Federal Register, in which rules changes are published, and which can be ordered from the Government Printing Office, Washington, D.C. 20402, for \$25 per year.

Test Equipment Required

The purpose of proof-of-performance tests is **to determine that the equipment conforms to FCC technical standards and will give the customer the benefit of the equipment's full capability.** Here is where servicing mobile radio differs sharply from servicing TV sets and broadcast-band radios. The author

Table 4

PROOF-OF-PERFORMANCE TEST REPORT					
Customer.....		Call sign.....		License expiration date.....	
Make.....		Model.....	Serial No.	FCC Form 452-C attached....	
FCC type acceptance No. (if known).....		Date of previous test.....			
Test No.	TYPE OF MEASUREMENT	MEASURED RESULTS AT POWER INPUT VOLTAGE			REMARKS
		12.6 VDC or 110 VAC	13.8 VDC or 117 VAC	15 VDC or 125 VAC	
1	Input current				
1(a)	Standby (amps)				
1(b)	Receive (amps)				
1(c)	Transmit (amps)				
2	RF output (watts)				
3(a)	Transmitter frequency (MHz)				
3(b)	FM deviation, upward (KHz)				
3(c)	FM deviation, downward (KHz)				
4	Receiver sensitivity (μv)				
5(a)	Squelch sensitivity, minimum (μv)				
5(b)	Squelch sensitivity, maximum (μv)				
6(a)	Selectivity at + 6 KHz (dB)				
6(b)	Selectivity at - 6 KHz (dB)				
6(c)	Selectivity at + 30 KHz (dB)				
6(d)	Selectivity at - 30 KHz (dB)				
7	Image rejection at . . . MHz (dB)				
8	Spurious responses noted (MHz)				
9	Receiver frequency accuracy (KHz)				
10	IF amplifier symmetry (OK, not OK)				
11	Discriminator symmetry (OK, not OK)				
12	TVI observed (channels)				

Tests Conducted by on (date)

recalls that around 40 years ago in San Francisco, the typical proof-of-performance test of an AM broadcast-band radio consisted of tuning in KQW in San Jose and visually noting that it came in at the proper place on the dial.

Today, a mobile radio can be tested by communicating with a base station or another mobile unit to determine that it is capable of transmitting and receiving. But, that's not enough, because it could be off-frequency, radiating too much power and/or causing TVI (television interference). Unlike the situation in 1930, a wide variety of test equipment is available today. Table 3 lists the equipment that can be used for conducting proof-of-performance tests.

Recording Results of Tests

The results of proof-of-performance tests should be recorded on a form, an example of which is shown in Table 4. If the equipment is operable on more than one frequency, a separate form should be used for each frequency.

The completed forms should be kept in the shop's files for future reference and possible FCC examination. A carbon or photocopy can be given to the customer, if required.

Power Consumption

One of the important proof-of-performance tests is the measurement of input current at various input voltages and under standby, receive and transmit conditions. Both DC and AC variable-voltage power supplies, with built-in voltmeter and ammeter, are available in ready-to-use and kit form. Or, for checking 12-volt DC mobile units, a 12-volt storage battery, a battery charger and a voltmeter and ammeter can be used, as shown in Fig. 1. By turning the charger on and off, the voltage can be raised and lowered, but not as much as with a variable-voltage rectifier power supply. For checking AC-operated equipment, the set-up shown in Fig. 2 can be used.

Input Current

As noted in Table 4, the test record form has four columns for insertion of data. This enables re-

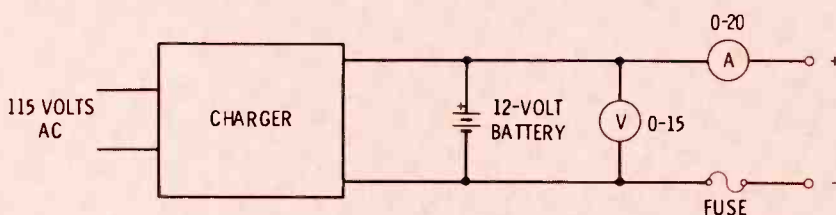

Fig. 1 A battery charger, 12-volt storage battery, voltmeter and ammeter are connected as shown to power mobile units that use 12-volts DC.

Precision Tuner Service

gives you
profit power

..with even
finer, faster,
Service!

WE HAD JUST REPRINTED OUR LITERATURE . . .
ADDING OUR THIRD NEW PLANT . . .
WHEN WE DID IT AGAIN . . . PRECISION TUNER SERVICE

ADDS

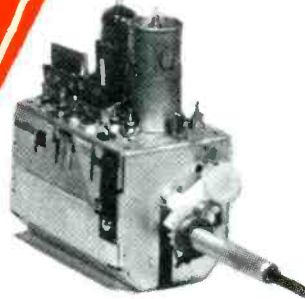

**does
its
thing**

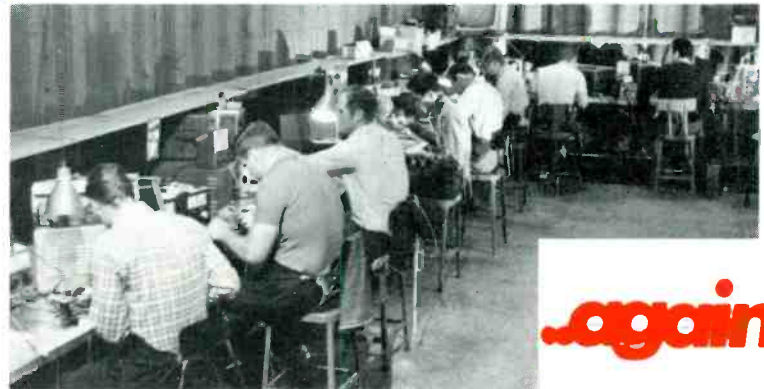

..again!

**For YOU:
MORE &
FASTER
PROFIT**

YOU can offer this specialized, expert service. Quality Tuner Service is our bag, man! Experienced, conscientious PTS craftsmen with sophisticated, precision (and expensive) tools and equipment mean faster PROFIT for you with PTS 8-hour service. . . .

TURNOVER

. . . . No doubt about it! PTS mails your tuner back the SAME DAY it is received! Now less in-transit time, too!

**Precision
Tuner Service**

FREE JOB CARDS FREE SHIPPING LABELS

**8 Hr.
Service**

. . . and
now with
even
shorter
in-transit
time!

VHF or
UHF

\$8.95

UV Combo's

\$14.95

Major Parts, Tubes,
Transistors
charged at Net Price

**CUSTOMIZED REPLACEMENTS AVAILABLE
FOR \$12.95 UP (NEW OR REBUILT)**

FIRST TO OFFER 365-DAY GUARANTEE!

COLOR — BLACK & WHITE — TRANSISTOR TUNERS — ALL MAKES
GUARANTEED COLOR ALIGNMENT — NO ADDITIONAL CHARGE

For fastest service, send faulty tuner with tubes, shields and all broken parts to:

HOME OFFICE—	Box 272—Bloomington, Ind. 47401	Tel. 812/824-9331
EAST—	Box 334—W. Springfield, Ma. 01089	Tel. 413/734-2737
SOUTHEAST—	4451 N.W. 37th Ave., Miami, Fla. 33142	Tel. 305/633-0002
SOUTHWEST—	Box 7332—Longview, Tex. 75601	Tel. 214/753-4334
WEST—	Box 1431—Turlock, Calif. 95380	Tel. 209/632-2928

Circle 21 on literature card

coding of results at three different input voltages (12.6 volts DC or 110 volts AC, etc.); special conditions should be noted in the "Remarks" column.

First, connect to the transmitter an RF wattmeter equipped with either built-in or plug-in 50-ohm load, as shown in Fig. 3, or a standing-wave-ratio (SWR) meter (thru-line RF wattmeter) with 50-ohm dummy load connected, as shown in Fig. 4, and with the meter set to read forward power. Then turn the equipment on and measure and record input current with the unit in receive position but

squelched (no noise in speaker), then with the squelch disabled (noise in speaker), and finally with the transmitter turned on, with either 12.6 volts DC or 110 volts AC applied. Repeat the test with 13.8 volts DC or 117 volts AC applied, and then with 15 volts DC or 125 volts AC applied. Make all other tests at each of the three input voltages.

RF Output

While making the preceding input-current measurements, also observe and record RF power output readings. If lower than normal, at

rated input voltage, retune or repair the transmitter, and repeat the tests. Key the transmitter on and off several times to make sure the oscillator is stable.

Frequency Measurement

After the input-current and RF-output tests are completed and found satisfactory, measure the transmitter frequency. Loosely couple the transmitter and frequency meter, as shown in Fig. 5. In lieu of the indicated 50-ohm dummy load, you can leave the RF wattmeter or SWR meter (with dummy load) connected to the antenna connector of the transmitter. Or you can connect the frequency meter directly to the transmitter, as shown in Fig. 6. Some frequency meters are furnished with coupling devices other than those shown; always use the coupling devices furnished with the meter. An electronic counter can be used to measure frequency, using the same hook-up in Fig. 6, unless the electronic counter manual specifies otherwise. Record the actual frequency measured (in MHz), with each of the three different input voltages applied.

Modulation Measurement

If a combination frequency and FM deviation meter is used, note and record FM deviation while talking loudly into the microphone. It should not exceed, but should approach, 5 KHz. Or, use an FM deviation meter or oscilloscope-type FM analyzer, and record the deviation observed. If the instrument can measure both upward and downward FM deviation, record both readings. (They should be the same.)

To check transmitter frequency response and modulation limiting, connect an AF signal generator through an attenuator to the transmitter's microphone input. In addition to watching the deviation meter, with a VTVM or scope measure the AF voltage at the AF input of the phase modulator. Tune the AF signal generator from 90 Hz to 10,000 Hz, at various levels, and note if the indicated FM deviation and AF voltage fall off above 3000 Hz. Also, at 1000 Hz, and again at 3000 Hz, note if FM deviation can be made to exceed 5 KHz. If it

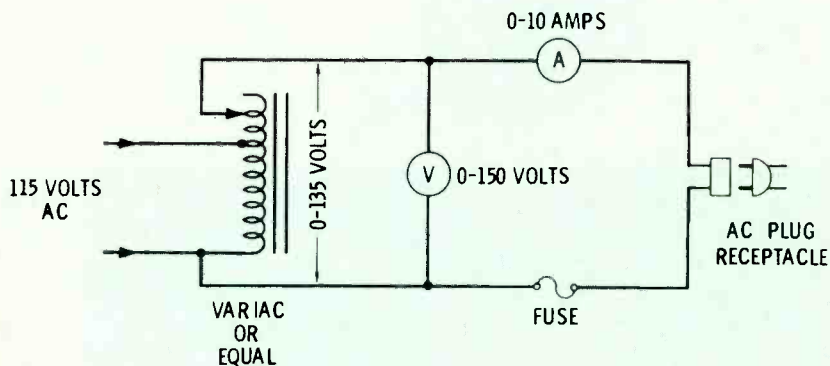

Fig. 2 Setup shown here is used to power AC-operated equipment, such as that employed in base stations.



Fig. 3 Input current and power output measurements using an RF wattmeter with built-in 50-ohm load.

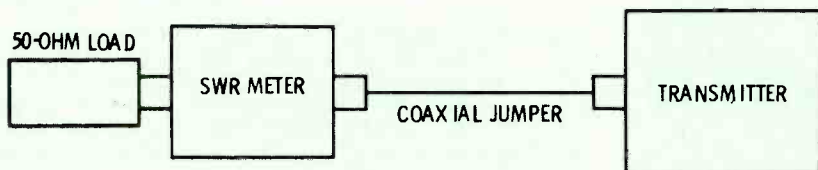

Fig. 4 Input current and power output measurements employing a standing-wave-ratio (SWR) meter with external 50-ohm dummy load.

doesn't exceed 5 KHz when you shout into the mike, modulation limiting is satisfactory.

A further check of modulation can be made by using the setup shown in Fig. 7. Tune in the transmitter signal on an FM monitor receiver to whose speaker terminals a scope has been connected. Then, repeat the frequency response and modulation-limiting tests, and observe the audio waveform. With the modulation turned off, but with the carrier on, listen for carrier hum and noise (or watch for hum on the scope). Note: Allow for distortion contributed by the monitor receiver.

Television Interference

Place a TV set, with rabbit ears or built-in monopole antenna, in the same room as the transmitter (connected to a dummy load). As you switch the TV set from Channel 2 through Channel 13, key the transmitter on and off and watch the TV screen for any indications of television interference (TVI). Then, leave the transmitter on and tune the TV set through all UHF TV channels while watching for TVI.

Repeat the test with the transmitter connected to the shop's test antenna, as shown in Fig. 8. (But, first tune the transmitter to the antenna with an SWR meter.)

At such close range, TVI could be severe. If so, move the TV set farther away, but not more than 50 feet. If TVI then persists, connect a wave trap, tuned to the transmitter frequency, to the antenna terminals of the TV set. If this stops or sharply reduces TVI on Channel 2 (for 30-50 MHz transmitter), or Channel 13 (for 150-174 MHz transmitter), you will know that TVI undoubtedly is caused by lack of adequate TV receiver front-end selectivity, rather than spurious transmitter emissions.

Receiver Sensitivity

To measure receiver sensitivity, connect a laboratory grade VHF-UHF/FM signal generator to the receiver input, as shown in Fig. 9. Tune the signal generator to the receiving frequency, as indicated by maximum voltage reading on a VTVM connected to the receiver limiter test point, and hearing of the

modulation tone in the speaker. When tuned correctly, the VTVM connected to the receiver discriminator should indicate zero with signal generator modulation turned off.

Next, reduce the signal generator output to zero, so noise will be heard in the speaker (squelch disabled). Note the level of the noise, as indicated by a VTVM connected across the speaker terminals. Increase the signal generator output (unmodulated) until the AF output

level (noise) drops 20 dB (1/10th the initial voltage). Note the signal generator output level controls (in microvolts). Because of the 50-percent voltage drop across the 47-ohm resistor connected in series with the signal generator output and receiver input, the actual sensitivity for 20 dB quieting is twice the microvolts indicated on the signal generator. Record the indicated sensitivity at each of the three applied input voltages.

Fig. 5 Loose-coupled setup for making transmitter frequency measurements.

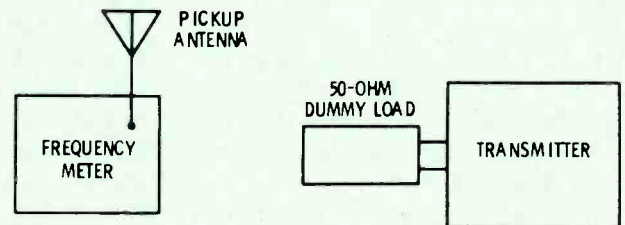

Fig. 6 Setup for making transmitter frequency measurements with frequency meter direct-coupled through an attenuator to the transmitter output.

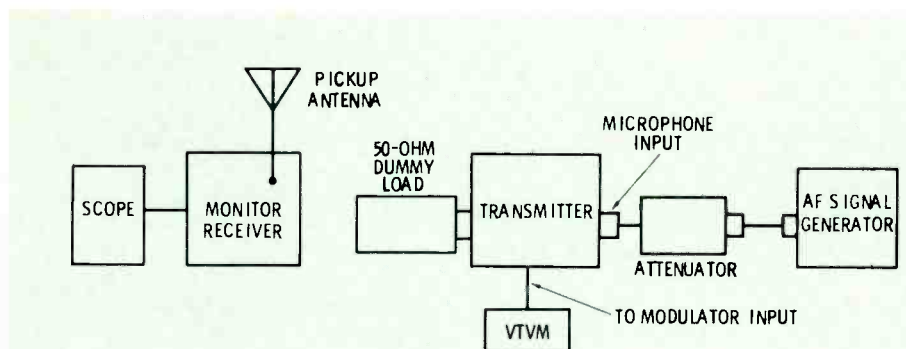
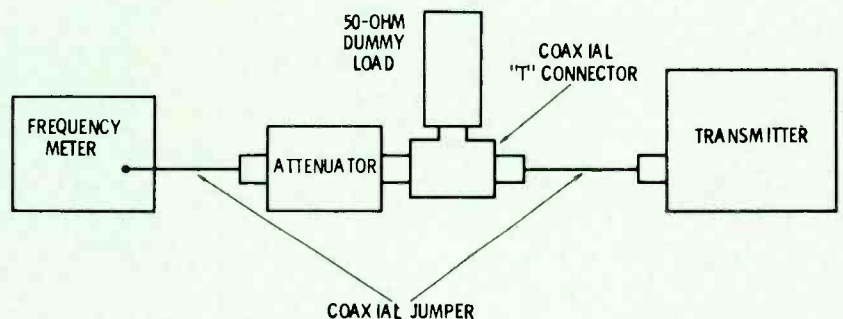

Fig. 7 Equipment setup for measuring transmitter audio-frequency response and observing distortion.

To determine sensitivity at rated audio output, frequency-modulate the signal generator at ± 5 KHz and adjust the signal generator output level until the voltage at the speaker terminals indicates rated audio output. For example, if rated audio output is 1 watt and the speaker impedance is 4 ohms, the audio level will be 2 volts ($E = \sqrt{WR}$).

Limiting action can be measured by slowly advancing the signal generator output and observing the VTVM connected to the limiter test point. Increasing signal generator output beyond a certain point will cause limiter voltage to level off or increase slowly, and audio output should remain relatively constant. It is the FM deviation, and not signal amplitude, that causes the AF output to increase when the receiver limiters are saturated.

(Another technique for measuring

receiver sensitivity is the SINAD method, which requires the use of more sophisticated equipment than normally available in the typical mobile radio shop.)

Squelch sensitivity is another important test related to overall receiver sensitivity. The "effective" sensitivity of a receiver can be preset by adjustment of the squelch control. For maximum sensitivity, the squelch control is set just beyond the point where the speaker is silenced when no signal is being received. Operationally, however, the squelch control is usually set so that the speaker will be muted except when a signal is intercepted which will produce a certain signal-to-noise ratio.

To check squelch sensitivity, do the following: 1) Connect the equipment as shown in Fig. 9; 2) set the squelch control just beyond the noise muting point; 3) apply a fre-

quency-modulated signal to the receiver; 4) adjust signal generator output to trip the squelch, and note signal generator output level; 5) reduce signal level and note signal level at which squelch silences speaker; 6) set squelch control to **least** sensitive position; 7) vary signal generator output level and note cut-in and cut-out levels.

Receiver Selectivity

To measure receiver selectivity, reduce the signal generator level until the limiter voltage is **below** its **peak** level, but at a convenient reference level. Then, tune the signal generator (unmodulated) 6 KHz higher than the receiving frequency, and increase the output signal level until you get the same limiter voltage reading. Note the signal generator level-control settings. Then tune the signal generator 6 KHz **lower** than the receiving frequency. For example, if the signal-generator level is now twice as high at the ± 6 -KHz points, the 12-KHz bandpass selectivity is 6 dB. Repeat with the signal generator set 30 KHz higher and then 30 KHz lower than the receiving frequency. If, for example, the level of signal required to produce the same limiter voltage is now 10,000 times higher than the level required at the exact receiving frequency, the selectivity at 30 KHz will be 80 dB.

Image and other spurious responses can be measured in the same manner. Tune the signal generator through a wide frequency range and note any effect on receiver limiter voltage. At frequencies where the acceptance of a spurious signal is noted, adjust the signal generator output level to obtain the same limiter reference voltage as obtained at the receiving frequency. Note how much more signal is required. Expressed in dB, this is the amount of **spurious rejection**.

In lieu of measuring limiter voltage, AF output voltage can be monitored. With the signal generator set to the receiving frequency, and its level set to drop background noise 20 dB, adjust the signal generator output level to produce 20 dB of quieting at the other frequencies.

A more meaningful selectivity test can be made by using two RF signal generators, connected as

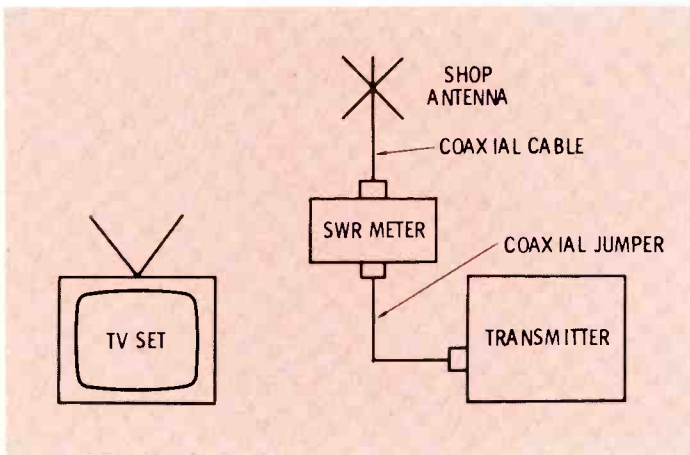

Fig. 8 Setup for checking interference (TVI). Screen of TV set is monitored while transmitter is keyed.

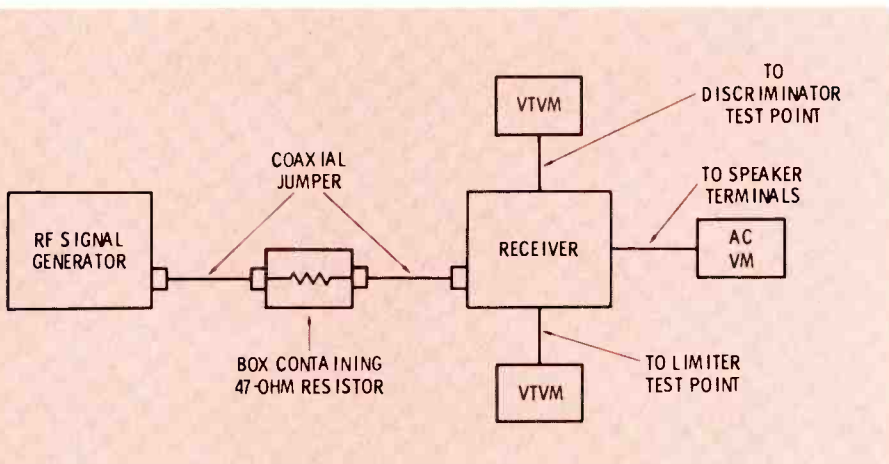
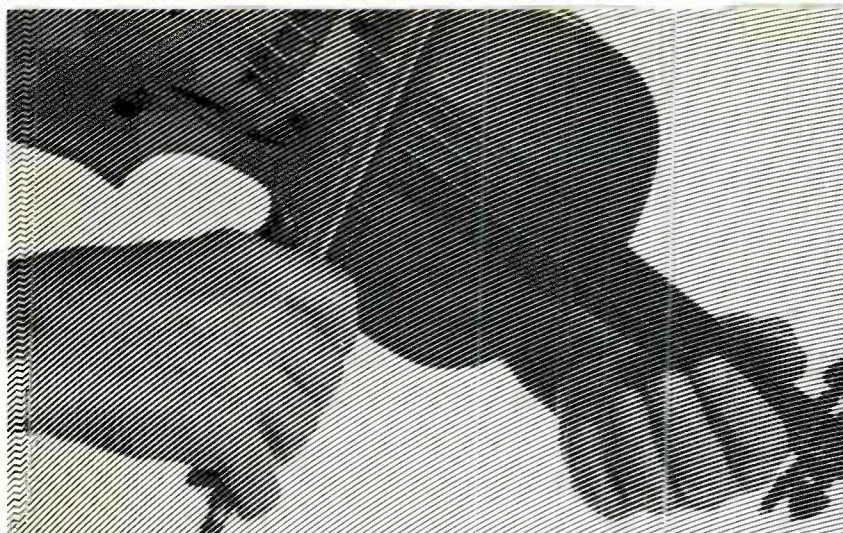

Fig. 9 Equipment setup for receiver sensitivity, selectivity and spurious response tests. Signal generator should be laboratory grade VHF-UHF/FM type.



**professional
hands require
years of training**

**professional TV
service dealers insist on
GE ULTRACOLOR picture tubes
(made by professionals for professionals)**

GENERAL  ELECTRIC

**TUBE DEPARTMENT
OWENSBORO, KENTUCKY 42301**

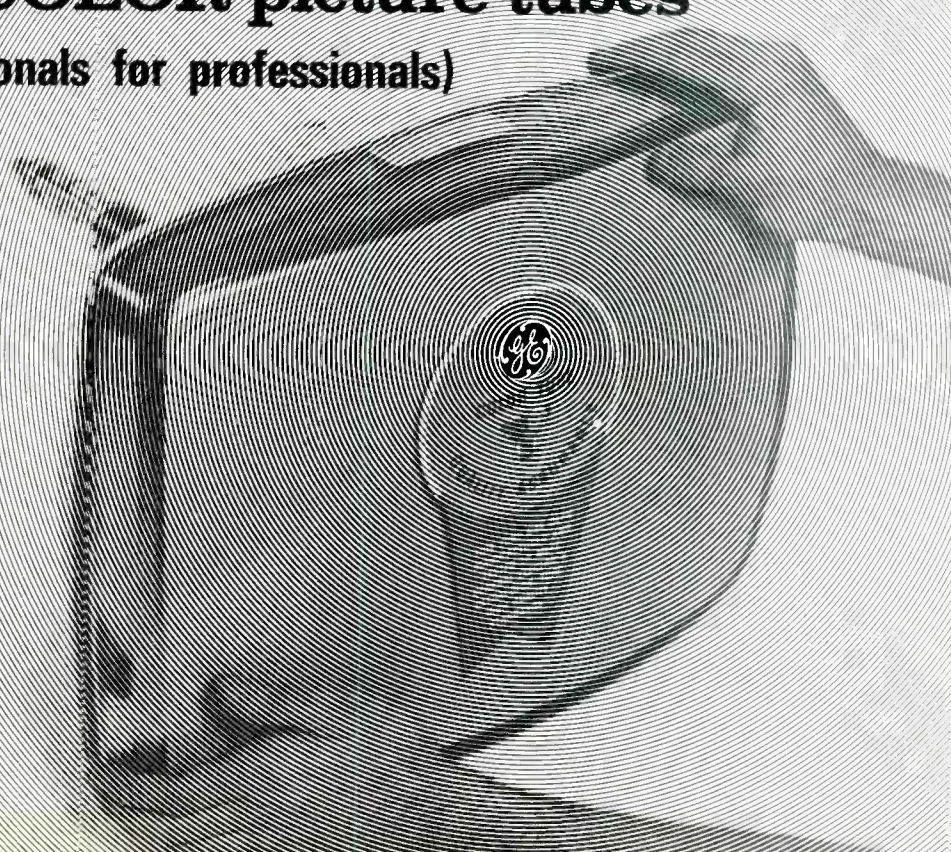

shown in Fig. 10. Tune one signal generator to the receiving frequency, with the level set to provide a relatively low limiter reference voltage. Tune the other signal generator 30 KHz higher or lower than the receiving frequency, and adjust its output until the limiter voltage is doubled (6 dB). This is the level of adjacent channel signal required to capture the receiver intercepting an on-channel signal. The 30-KHz frequency difference is applicable to the 150- to 174-MHz band, in which most channels are spaced 30 KHz apart. In the 30- to 50-MHz band, tune the second signal 20

KHz higher or lower than the receiving frequency; tune it 25 KHz higher or lower in the 450- to 470-MHz band.

Another way to check adjacent-channel selectivity is to tune one signal generator (unmodulated) to the receiving frequency, and set its level so that it produces 20 dB of noise quieting. Then, the other signal generator (modulated) is tuned to either adjacent channel frequency (30 KHz higher or lower than receiving frequency). Its level is increased until its tone modulation is heard. This is what is encountered in actual operation.

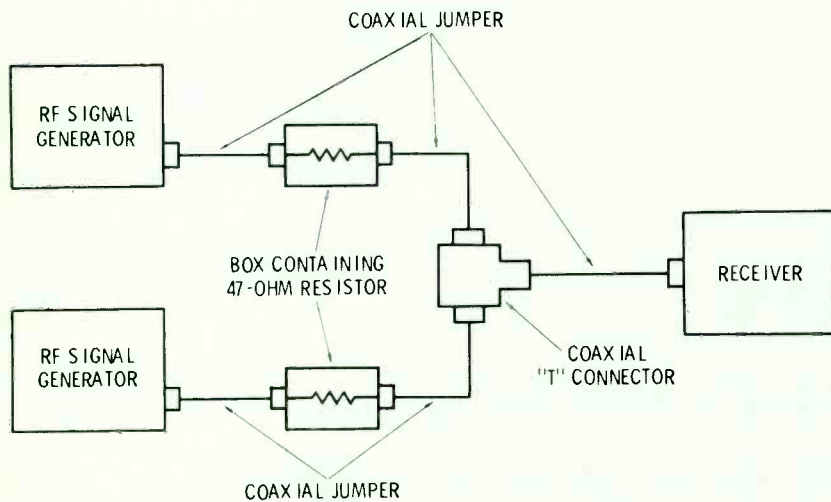

Fig. 10 More meaningful receiver selectivity test can be made with two RF signal generators, one tuned to receiving frequency, the other either 30 KHz higher or lower than receiving frequency.

Receiver Frequency Accuracy

A transmitter can be set almost exactly on frequency by adjusting the crystal padder (variable capacitor or inductor) while using a frequency meter or electronic counter as the frequency indicator. For example, if the transmitter carrier frequency is 151.925 MHz and FM deviation is ± 5 KHz, the radiated signal will extend from 151.920 to 151.930 MHz (not including other modulation products).

The 1st local oscillator signal (from multiplier) of a distant receiver, as shown in Fig. 11, should be at 162.625 MHz (or 141.225 MHz) to produce a 10.7-MHz 1st IF signal. The 2nd local oscillator should operate at 10.245 MHz (or 11.155 MHz) to produce a 455-KHz 2nd IF signal. The discriminator should see a signal at almost exactly 455 KHz when no modulation is present, and one that varies symmetrically from 455 KHz to 460 KHz and from 455 KHz to 450 KHz.

If the 1st local oscillator signal is 1 KHz too high (162.626 MHz), the 1st IF signal will be at 10.701 MHz. And, if the 2nd local oscillator operates 1 KHz too low (10.244 MHz), the 2nd IF signal will be at 457 KHz instead of 455 KHz. This means that the discriminator will see a signal varying from 457 KHz to 462 KHz and from 457 KHz to 452 KHz, an error of 0.44 percent.

The problem can be corrected by tuning the IF amplifier and discriminator to 457 KHz instead of 455 KHz. But, if the selectivity filter is very sharp, the amplitude of signal swings above 460 KHz could be significantly attenuated.

When the 1st local oscillator is provided with a crystal padder, the error in the 1st IF signal frequency can be corrected. But the frequency of the 2nd local oscillator is seldom adjustable.

The accuracy of local oscillator frequencies can be checked by using the setup shown in Fig. 12. An unmodulated signal at the receiving frequency is fed from a frequency meter to the receiver input. (A tunable signal generator is too inaccurate for this purpose.) A 455-KHz unmodulated signal is loosely coupled to the output of the 2nd mixer. If the 2nd IF signal is not almost

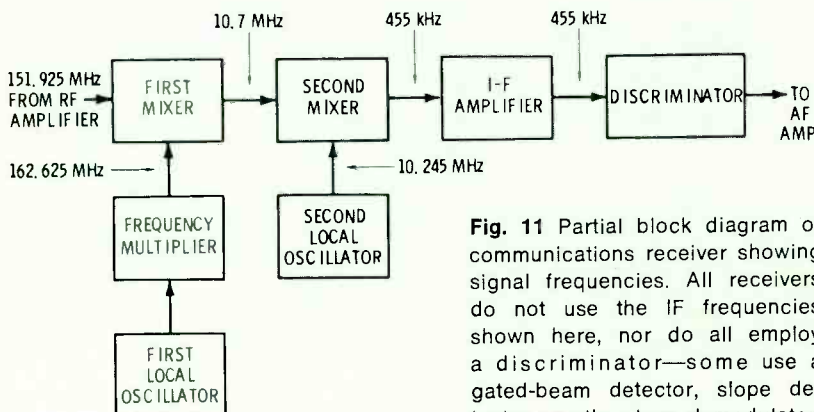

Fig. 11 Partial block diagram of communications receiver showing signal frequencies. All receivers do not use the IF frequencies shown here, nor do all employ a discriminator—some use a gated-beam detector, slope detector or other type demodulator.

exactly at 455 KHz, an audio beat note will be heard in the speaker. The amount of frequency error can be measured with an electronic counter connected to the speaker terminals.

When a 1st local oscillator crystal padder is included, adjust its frequency so the resulting 2nd IF will be almost exactly at 455 KHz, as indicated by zero beat in the speaker.

IF and Discriminator Symmetry

To check IF amplifier and discriminator symmetry, a crystal oscillator operable at 450, 455 and 460 KHz can be used (see Fig. 12). Connect a DC VTVM, set for zero indication at center scale, to the discriminator test point. Set the test oscillator to 450 KHz and then to 460 KHz. If the IF bandpass and discriminator are symmetrical, the VTVM will indicate the same amplitude, but opposite polarity, of voltage at both frequencies.

Receiver Netting

A mobile radio system should be "netted" so that all mobile unit receivers are tuned as precisely as possible to the base station frequency. Obviously, all mobile transmitters should be adjusted as closely as possible to the assigned carrier frequency. And, the base station receiver should be trimmed to this frequency.

When conducting proof-of-performance tests, receivers should be adjusted for best response to the base station they are to receive. This can be done by using a frequency meter to furnish the reference signal. But, in usual practice, the base station signal is picked up by an antenna, as shown in Fig. 13. A 2nd IF comparison signal is loosely coupled to the 2nd mixer and the receiver is adjusted for zero beat of the actual IF signal and the IF comparison signal. Also, the discriminator is zeroed against the base station signal.

(NOTE: For the sake of easy explanation, 10.7 MHz and 455 KHz have been referred to as 1st and 2nd IF signal frequencies. However, all receivers do not use the same IF signal frequencies, nor do all employ a discriminator as an FM de-

tektor—some use a gated-beam detector, slope detector, etc.)

On-The-Air Tests

Proof-of-performance tests usually are conducted in the shop. But, the final test can be an actual operational test. In the shop, connect the unit to an actual antenna system. Tune the transmitter to the antenna system, using an SWR meter connected as previously shown in Fig. 8. Then note receiver performance, such as sensitivity to weak signals, evidence of adjacent channel and intermodulation interference, susceptibility to ignition noise, etc. Check transmitter performance by communicating with the licensee's base station or mobile units.

When reinstalling the equipment, retune the transmitter to its own antenna system, again using an SWR meter. Also, adjust the receiver input circuit for maximum sensitivity to a weak off-the-air signal while monitoring limiter voltage. ▲

(NOTE: Do not operate a transmitter on-the-air without the consent of the licensee, and then only in accordance with FCC rules which include 1) limiting the duration of test transmission, and 2) proper identification by call sign.)

Summary

For the sake of expediency, most shops make necessary repairs and adjustments to restore equipment operation in the shortest amount of time. But, when time permits, and as a periodic routine operation, they conduct proof-of-performance tests. It's the professional way.

When a customer has spare sets, put them through the tests, record the results, and store them, protected by plastic bags, ready for use when required.

More comprehensive tests are usually conducted by mobile radio equipment manufacturers, but those discussed here are applicable to the servicing profession, and are more qualitative than quantitative. ▲

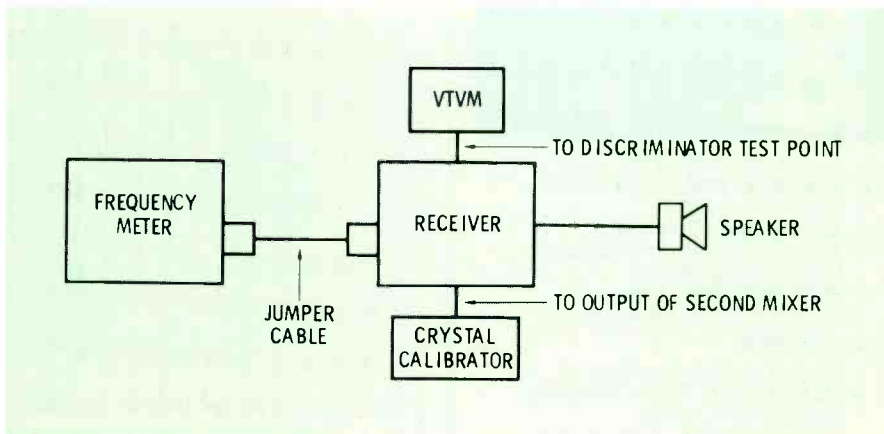
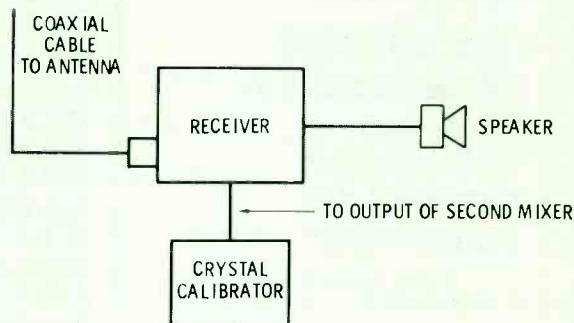

Fig. 12 Setup for checking receiver frequency accuracy and IF-discriminator symmetry (even response).

Fig. 13 Setup for "netting", or precisely tuning, a mobile unit receiver to the base station frequency. Crystal calibrator is tuned to produce a 2nd IF signal, which is heterodyned (beat) against the 1st IF signal in the 2nd mixer.



passivated rectifier



GE-509



- Up to 1000 volts PIV
- Transient Voltage Protection
- Passive Junction
- All Diffused Structure
- High Surge Current Capacity
- Hermetically Sealed
- Dual Heat Sink Design
- Low Thermal Impedance

applications:

- Free-Wheeling Rectifier
- TV and Radio Power Supplies
- Time-Delay Circuits
- Communications Equipment
- Power Logic Circuits
- SCR Trigger Circuits
- ARC Suppression
- Small Portable Appliances
- Battery Chargers
- General Purpose Power Supplies
- TV Damper Diodes
- Low Level Limiters

your authorized
GE distributor can
fill all your
entertainment
semiconductor
requirements

TUBE DEPARTMENT
OWENSBORO, KENTUCKY

GENERAL  ELECTRIC

Circle 23 on literature card

antenna systems report

Fold-Down Marine CB Antenna

A marine antenna for citizens radio service, said to produce a low angle of radiation, has been introduced by the Antenna Specialists Company.

Model M-223 is a center-loaded, eight-foot whip, constructed of high-resiliency 17-7 PH stainless steel,

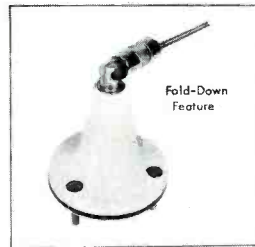

with chrome-plated brass hardware and a high-impact cyclolac base for maximum environmental resistance, according to the manufacturer. The double-loaded, half-wave antenna requires no ground plate, thus simplifying installation and maintenance.

Two additional models, M-221 and M-222 also have been added to the firm's marine line. Model M-221 is a six-foot version of M-223, with identical construction features. Model M-222 is a three-foot, self-supporting white fiberglass antenna of full quarter-wave length with similar fittings and hardware. A ground plate is recommended by the manufacturer for this antenna unless it can be mounted on a large flat metal surface.

Models M-221 and M-223 are list priced at \$29.95, while Model M-222 sells for \$19.95.

Circle 55 on literature card

Single-Channel Preamplifiers

A new line of highly selective, solid-state, single-channel preamplifiers for all 82 channels has been introduced by JFD Electronics Corp., Systems Division.

Using silicon transistor circuitry, the units reportedly can handle input signals twice as strong as those that overload conventional preamplifiers, according to the manufacturer.

JFD states that they provide 20 dB gain on all UHF channels, 20 dB gain on VHF channels 7 through 13 and 16 dB gain on VHF channels 2 through 6. Adjacent VHF channels are attenuated by 15 dB (15 dB down 6 MHz from edge of desired channel). Since UHF channels are not so closely spaced, the JFD UHF preamplifiers attenuate by 15 dB UHF frequencies three channels away. JFD also reports that noise figure is 5 dB on channels 2 through 6, 6 dB on channels 7 through 13 and 9 dB at UHF frequencies. Input and output impedances are 75 ohms.

Each unit is comprised of a mast-mounted single-channel preamplifier in an unbreakable molded plastic case and an indoor remote power supply. The output of the remote



power supply can be fed directly into a single-channel or broadband amplifier, or mixed with other channels through a filter network.

The new series are designated Model numbers SP-2802 through SP-2883, with the last two digits indicating the channel number. The SP-2888 handles the entire FM spectrum. The units list for \$75.00.

Circle 56 on literature card

VHF Marine Antennas

A new line of VHF marine ship-to-shore communications antennas is now available from Hy-Gain Electronics Corp.

The line includes four new shipboard antennas and three shore station antennas. All shipboard antennas are constructed of marine fiberglass and chrome-plated brass fittings. The entire line covers the VHF frequencies from 156 MHz through 163 MHz. A complete line of shipboard marine antenna mounts also is available.

Other features common to the entire line reportedly include top electrical performance without groundplates, and factory precision tuning so that any length of coax feedline will work.

Model 768, with 3 dB gain, is 54 inches long. It comes complete with 20 feet of coaxial cable and PL-259 connector. It is designed to be mounted with Hy-Gain Model 717 laydown mount.

Model 769 measures 9 feet and features 6 dB gain. It includes 20 feet of coaxial cable and the PL-259 connector. It mounts on the

Hy-Gain Model 718 laydown mount.

Featuring a 21-foot length and 9 dB gain, Model 770 is a system of stacked dipoles in a fiberglass radome. This model reportedly achieves both antenna elevation and increased gain by utilizing the entire length for radiation.

Designed for use as a sailboat antenna, Model 771 provides 3 dB gain and is suitable for mounting atop a ship's mast. It comes complete with the mast bracket, 60 feet of coaxial cable and a PL-259 connector.

Model 714 is a shore station antenna which provides 9 dB gain. The radiating elements are completely encased in a plastic radome.

Two additional shore antennas are available: Model 731, which features 3.4 dB gain; and Model 758, with unity (1) gain.

Model 768 is priced at \$40.00; Model 769 sells for \$60.00; Model 770 costs \$130.00; and Model 771 lists for \$50.00.

The shore station antennas range in price from \$7.95 for Model 596 to \$185.00 for Model 714. ▲

Circle 57 on literature card

Johnson announces the first dual receive CB base station. Lets you monitor Emergency Channel 9 while working another channel!

If you're an emergency monitor, imagine the impossible:

You're operating with another base or mobile on your "work" channel—or any channel other than nine. Someone in trouble transmits in your area on Emergency Channel 9 . . . What happens?



First, the emergency signal is detected through a separate channel nine receive section and superimposed through your speaker. You hear the emergency. Simultaneously a warning light illuminates on the panel. You see the emergency. You switch your basic transceiver to Channel 9 . . . work the emergency . . . and return to business.

Simple? For you—yes, thanks to Johnson advance research which began long ago to develop for you an immediate answer to the problems as well as the public service opportunity of Emergency Channel Nine. Write for complete specifications.

Features

- ± 3 kHz Delta fine tuning • Adjustable microphone gain with modulation adjustment to 100% • 2½" four-way professional meter, measures SWR, output, % modulation and receive • 4.3 MHz crystal filter for unequalled selectivity • Built-in speech compression • Panel-controlled, series-type threshold noise limiter • Built-in tone control • Built-in 117 VAC/12 VDC power supply • FET for superior gain • Two separate receivers with independent squelch controls



Messenger 124-Nine by



E. F. JOHNSON COMPANY

WASECA, MINNESOTA 56093

Circle 24 on literature card

RCA's TV Remote

THEORY OF OPERATION AND TROUBLESHOOTING

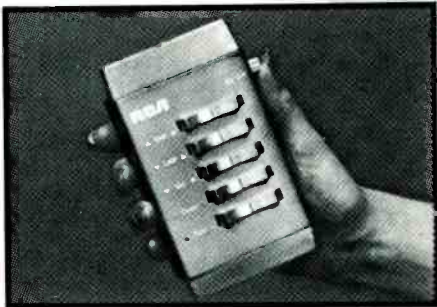
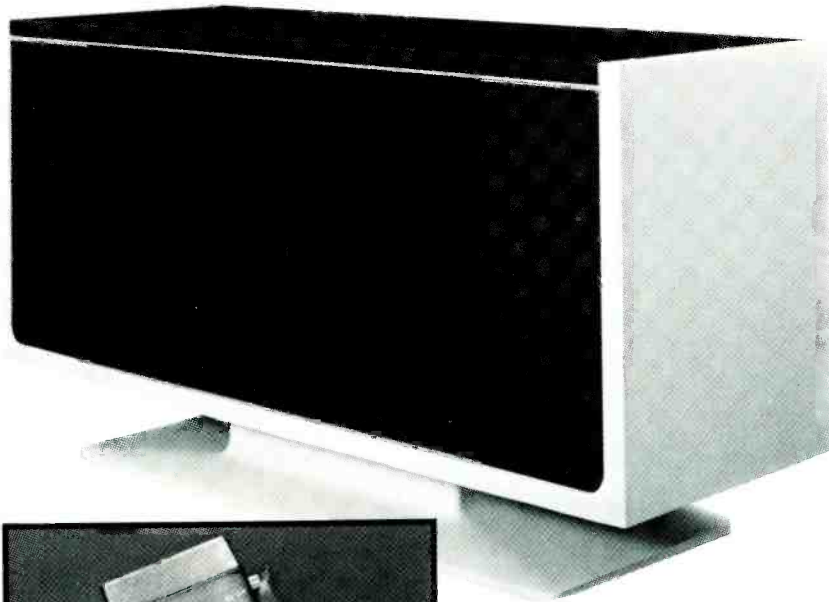

by Bruce Anderson

The only motor in RCA's remotely controlled CTC47 color TV chassis is the UHF tuning motor; remote control of VHF channel selection, the on/off function and adjustment of volume, tint and color saturation is accomplished electronically without motors.

How the volume, tint and color saturation remote control circuits operate will be explained in this article, along with techniques for tracking down troubles in them.

How Functions Are Controlled

One of the basic differences between motor-controlled and motorless-controlled is the way in which volume, tint and color are made to vary. Because it is the most simple, let's start with volume control.

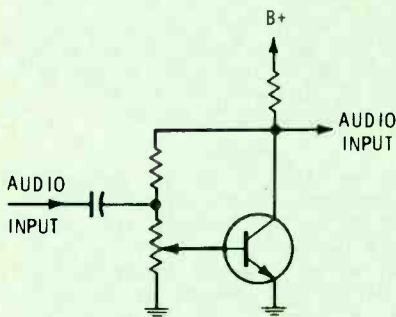

Fig. 1 Conventional volume control and audio amplifier

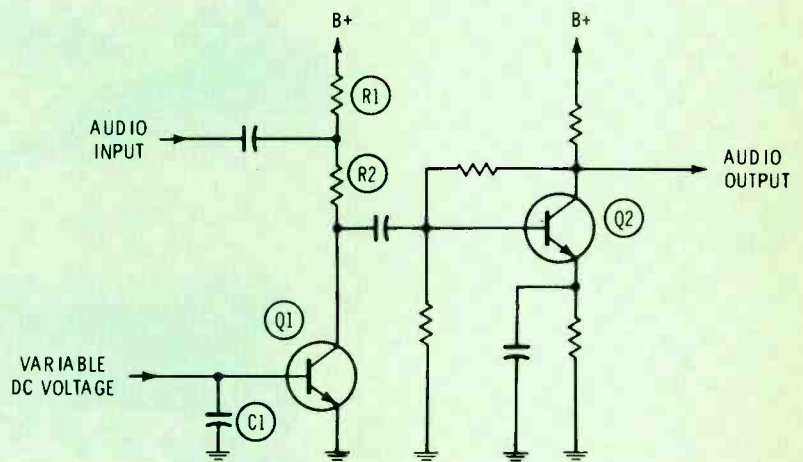

Fig. 2 Audio amplifier with DC volume control.

Control System

Fig. 1 illustrates the conventional method of controlling volume. The circuit itself is so simple that it requires no explanation; the point is that **something has to turn the shaft of the potentiometer.**

Now let's explore some alternate methods of controlling volume. If we were dealing with vacuum-tube circuits, we might use an audio-amplifier tube with remote-cutoff characteristics, and control its gain by varying the bias. This is similar to controlling the gain of an IF amplifier by varying the AGC bias applied to it. However, a couple of problems arise: First, remote-cutoff tubes tend to produce distortion when they are used with fairly high-level signals, such as those from the sound FM detector of a TV receiver; and second, tubes are no longer used in most television audio sections.

Controlling the volume by vary-

ing the bias of an audio-amplifier transistor also can lead to distortion problems, just as in vacuum-tube amplifiers.

There is, however, another approach: The use of a transistor as a signal-shunting device. The fundamental circuit is shown in Fig. 2. If the base-bias voltage of Q1 is zero, Q1 appears as an open circuit from collector to ground, there is no attenuation of the signal passing to Q2, and the output volume is maximum. However, as Q1 is biased into conduction, the impedance from collector to ground decreases, reaching nearly zero when Q1 is saturated. As the collector impedance of Q1 decreases, more and more signal is dropped across R2, and the volume is progressively reduced. If the supply voltage for Q1 is large in comparison to the signal, the instantaneous changes in collector voltage, caused by the signal,

will not have much effect on the impedance to ground, and significant distortion will not be produced.

This volume-control configuration actually has two advantages: One of these applies regardless of whether or not wireless remote control is anticipated. Because the audio signal itself does not need to be carried via wiring to the controlled stage, pick-up of hum and other spurious signals, which often occurs when a volume control is physically separated from the amplifiers, does not occur. Any stray AC voltages which might induce a spurious signal on the conductor leading to the base of Q1 will be shunted by C1, whose capacitance can be as large as necessary.

The second advantage is related to the first. Because the proposed remote-control system now needs to generate only a DC voltage, there is no need for a mechanical device.

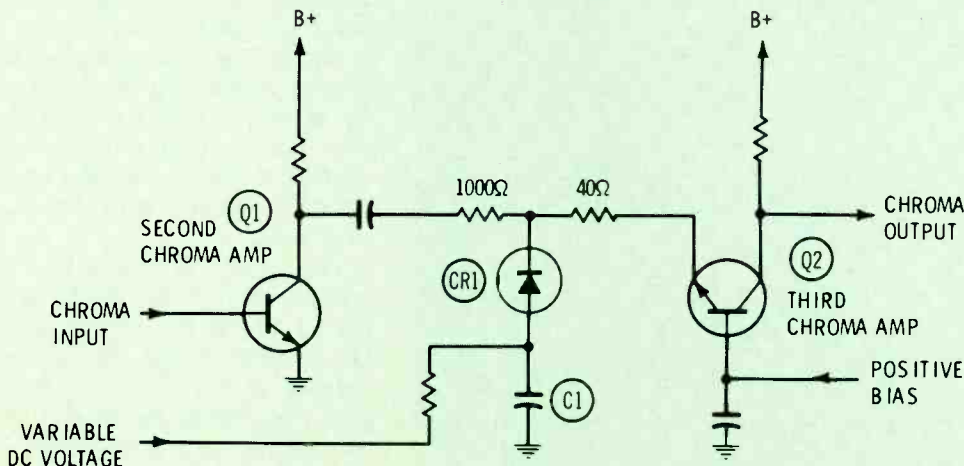

Fig. 3
Gain-controlled
chroma amplifier
using DC
control voltage.

Obviously, the circuit in Fig. 2 could be adapted to control color level instead of volume, since the functions are essentially the same.

In the RCA CTC47, the volume-control circuit is similar to Fig. 2, but the **active** devices are contained in an integrated circuit (IC).

A simplified version of the color-control circuit appears in Fig. 3. Diode CR1 is the signal-shunt device in this circuit. As the variable bias is made more positive, the impedance of CR1 decreases, again shunting more signal to ground and allowing less to pass to the 3rd chroma amplifier. As with the volume control circuit, there is no signal on the control line and spurious signals which might be picked up are grounded by C1.

Remote control of tint is a bit more complicated because the phase of a signal must be controlled, rather than its amplitude. A convenient way of doing this is to split the reference signal into two signals having different phases, separately control their relative amplitudes, and then recombine them.

In Fig. 4, reference signals from the 3.58-MHz oscillator drive the bases of Q1 and Q2 in phase; however, the RL emitter impedance of Q1 and the RC emitter impedance of Q2 cause the phases of the collector signals to be about 90 degrees from the input phase, respectively. Assuming the transistors are biased equally, each will supply half of the signal energy to the output transformer, and the combination of these two signals will produce an output in phase with the inputs to Q1 and Q2. (If the transformer secondary leads were reversed, the output signal would be 180 degrees out of phase with the input to Q1 and Q2.)

Now, suppose the variable bias is made more positive. Q2 will amplify more than before, and the phase of the output signal approaches the phase present at the emitter of Q2. At the same time, the increased current through Q2 increases the voltage drop across R1, biasing Q1 toward cutoff. If the variable bias is made less positive, the gain of Q2 will decrease,

the gain of Q1 will increase, and the phase of the output will shift in the opposite direction.

Memory Circuits

In a motor-driven remote-control system, the problem of memory does not arise, because once the motor comes to rest at the desired position, it will remain there. In a motorless system, the problem of memory becomes serious.

The circuit in Fig. 5, which has no memory capability, illustrates the point. Suppose the relay is closed by means of a hand transmitter and remote receiver. If R1 and C1 are very large, the voltage fed to the volume (or tint, or color) circuit will increase quite slowly, causing the volume to increase also. When the volume reaches a pleasant level, the operator releases the button and settles back to enjoy the program; however, C1 will gradually discharge through Q1 (of Fig. 2), and the volume again will increase back to maximum.

If discharge of C1 can be prevented, the volume will remain constant, once set, and memory will have been achieved. In Fig. 6, the basic configuration of a memory circuit is illustrated. In this circuit, the capacitance between gate and channel of the MOSFET, Q1, will charge towards B+ any time the contacts of K1 are closed. However, since the input capacitance of Q1 is about 5 pf, a charging resistance of several thousand megohms would be necessary to make the charging time long enough for a person to control it. To increase the charging time, C1 (about 1 mfd) is connected to ground.

Once the relay contacts are opened, there is **no** discharge path for C1 or the input capacitance of Q1, except through the leakage resistance of C1 and the MOSFET gate; this resistance can be made as high as several thousand megohms, and the time constant thus produced is in excess of several days, perhaps months. As we shall

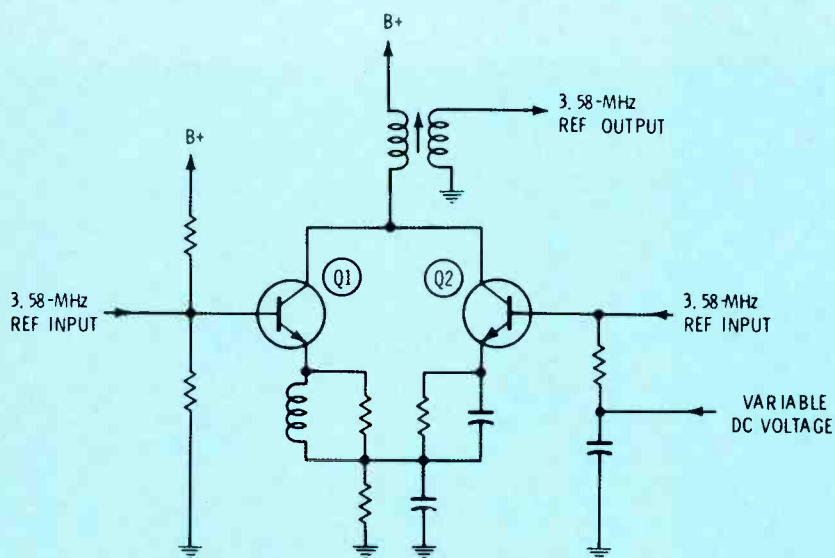

Fig. 4 DC-controlled tint circuit.

see later, this time can be extended even further. Q1 and Q2 serve as drain- and emitter-followers, respectively, to develop sufficient current-handling capacitance for the controlled circuit.

In addition to remote control, normally it is desirable to allow control of volume, tint and color at the receiver itself. One method of modifying the circuit of Fig. 6 to allow local control is to simply connect pushbutton switches across the "up" and "down" relay contacts. The use of remote controls which require that the button be depressed long enough for the function to change are acceptable, but people generally object to similar "time-consuming" controls located on the receiver itself. For some reason, a potentiometer type of control on the receiver is more pleasing. Also, as we shall see in the circuits described below, use of the potentiometer in the receiver improves the memory function.

In Fig. 7, C1 is returned to the wiper of a local-control potentiometer instead of ground; otherwise the circuit is the same as Fig. 6. However, in Fig. 7 the voltage on the gate of the MOSFET **will be almost exactly the same as the voltage at the potentiometer wiper**. This can be understood better if we consider C1 and the input capacitance as a voltage divider connected from the potentiometer to ground. Because the voltages across series capacitors are inversely proportional to their capacitances, and the value of C1 is about 200,000 times the input capacitance of Q1, essentially **all** the applied voltage is present on the MOSFET gate.

Assume that R1 in Fig. 7 has been set to produce normal volume, and +3 volts exists on the MOSFET gate. By actuating the remote "volume down" switch, the appropriate relay contact is closed and both C1 and the MOSFET input capacitance are charged to some higher voltage—in this example, 4 volts. Since the voltage **across** C1

is only 1 volt, instead of 4 volts as it would be in Fig. 6, the leakage current is one fourth as great, and memory is increased by a factor of four. (Since the gate resistance is almost infinite, the leakage current

through it can be ignored.) Furthermore, even if C1 leaks significantly, the volume will return to the original level determined by R1 instead of to maximum, to which it would return in Fig. 6.

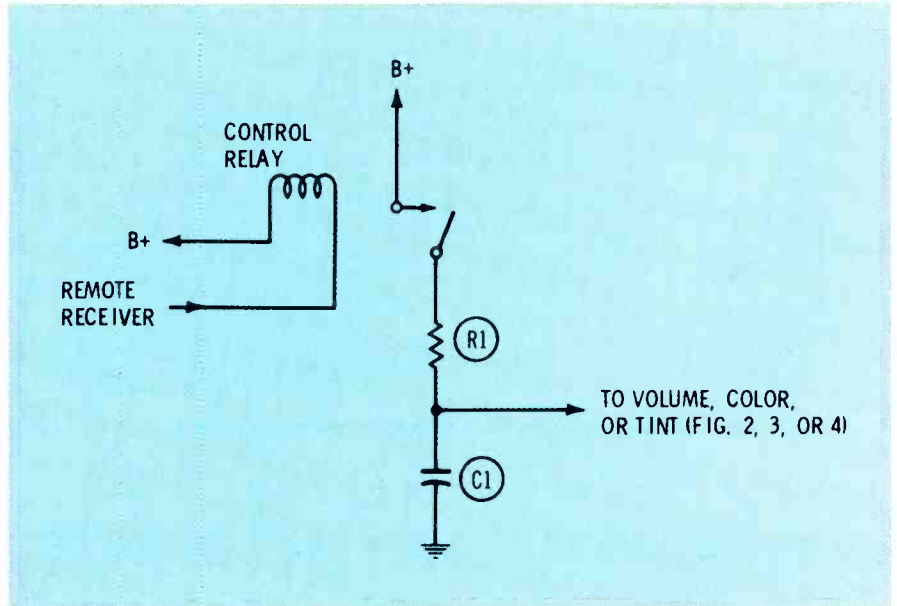

Fig. 5 Remote-control voltage source.

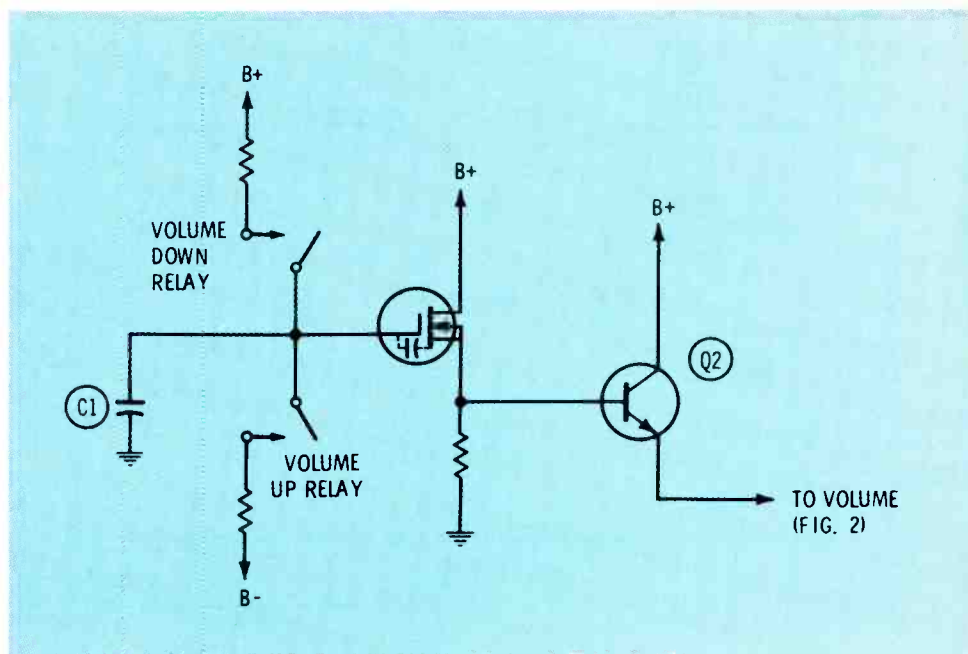

Fig. 6 Basic memory circuit and volume-control driver.

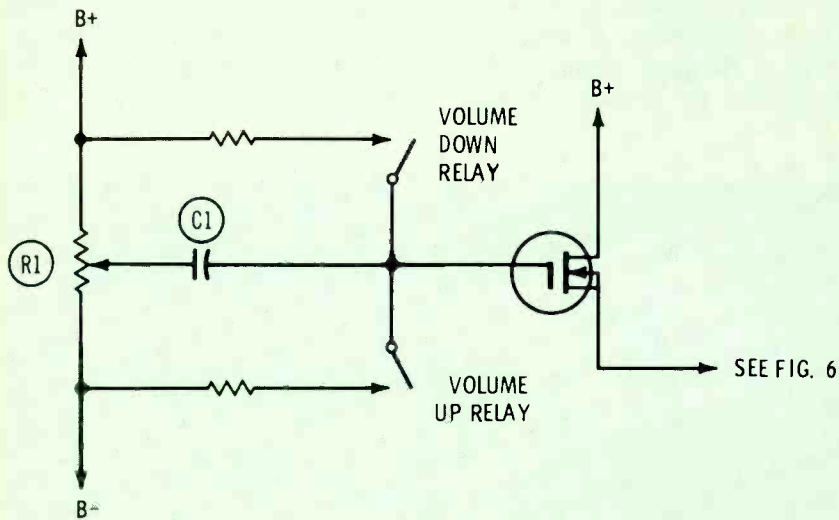

Fig. 7 Memory control circuit with local and remote inputs.

Electronic Switching

So far we have assumed relays were used to connect the voltage to the MOSFET. In the actual design, the relays have been replaced by electronic switches, as illustrated in Fig. 8.

When the "volume down" remote button on the transmitter is depressed, the transmitted frequency picked up by the remote receiver is the same as the resonant frequency of L1 and C1. At this frequency, the impedance of L1 and C1 is near zero and the current is large. The voltage across C1 is high, perhaps 200 volts, because it is equal to I (current) times Xc (capacitive reactance), and this ignites the neon lamp, I1. Once ignited, the resistance of I1 is low, and DC voltage from the B+ supply charges the MOSFET gate through R1, as already described.

One final circuit refinement is required, although it is not immediately apparent. If no means were provided to discharge C3 back to zero volts, enough voltage eventually would accumulate on C3, by virtue of the remote control, to make local control impossible. For example, suppose the local control originally had been set for a comfortable volume, and remote control subsequently was used to increase the volume. Then suppose local control were used to reduce volume, and remote control were used to raise it once more. After this had been repeated a number of times, the local-control potentiometer would be at its limit and volume still would be high.

To prevent this, the local-control potentiometer is constructed with a "delta switch", which closes momentarily each time the shaft is turned, even a few degrees. The delta switch energizes a relay whose contacts are connected across C3. Thus, each time the local control is used, all voltage resulting from remote control is cancelled, or discharged to the potentiometer wiper. With the addition of the delta

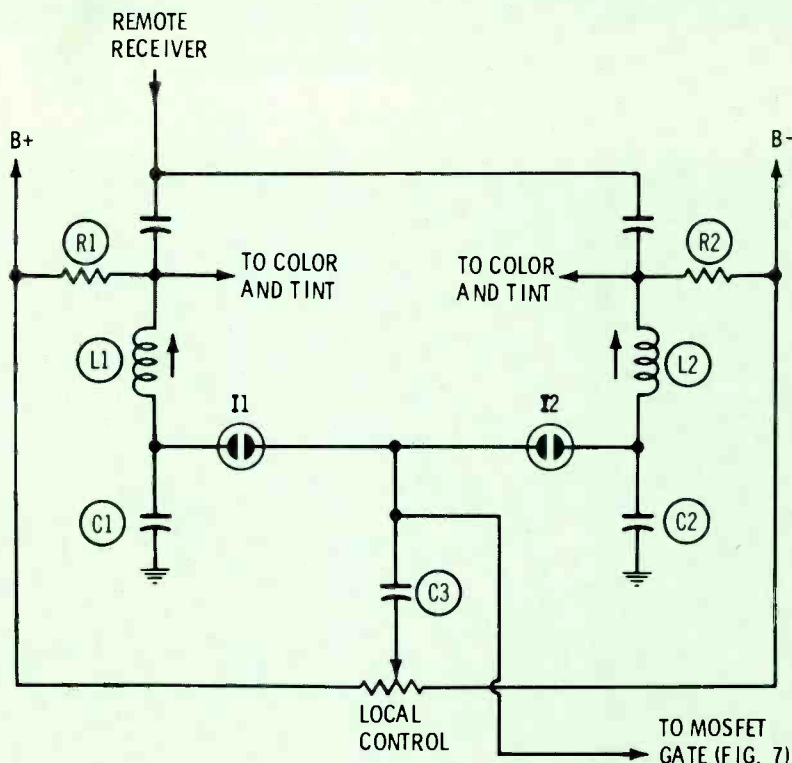

Fig. 8 Memory circuit input using electronic switches.

switch, either remote or local control can be used repeatedly in any sequence without a "hang-up" resulting.

Troubleshooting

In the CTC47 chassis, the MOSFET, C3, I1, I2 (Fig. 8), and the reset relay across C3 are sealed in a plug-in module, making these components impossible to test. However, it is conceivable that they or their counterparts might be exposed in a future design. For this reason, a few troubleshooting tips have been included here. At present, this module in the CTC47 can be checked by substitution or by removing it and connecting the potentiometer input terminal to the MOSFET output terminal, using a 1000-ohm resistor.

The first step in servicing motorless remote control is to determine if failure of the system to respond to a command is the fault of the **control** circuits or the **controlled** circuit. This can be done quickest by disconnecting Q2 in Fig. 6 from the volume-controlled circuit in Fig. 2 and supplying a variable voltage to the **controlled** stage from some other source. The wiper of the local-control potentiometer is a convenient source. If this restores operation, the **controlled** circuit is okay. If it does not, check the **controlled** circuit, using conventional troubleshooting techniques (voltage and resistance measurements, etc.).

If the control circuit is at fault, determine if both local and remote commands are inoperative or if only remote will not work. If only remote is out, check the **signal** voltage from the junction of L1 and C1 to ground. This should be about 150 to 200 volts, p-p. (The input resistance of the meter or scope must be at least 10 megohms, to prevent loading the circuit.) If this voltage is absent, check the remote transmitter and receiver, just as you would in a conventional system. If the signal voltage is **low**, check the tuning of L1 by adjusting for max-

imum signal with the transmitter button depressed (**Note:** insert an isolating resistor of about 5 megohms between C1 and the scope or meter. Otherwise, the probe capacitance will slightly detune the sensitive circuit.)

Other faults which will disable remote control, but not local control, include a shorted C3 (Fig. 8) or a shorted relay across C3. Also, if either neon lamp is **open**, the associated up or down remote function will not operate. If a lamp is **shorted**, both remote functions (up and down) will not operate, because memory will be destroyed; limited local control will be possible, but the **range** of control will be limited.

If both **remote and local** controls are inoperative, look for a failure in either Q1 or Q2 in Fig. 6. Disconnect the input to Q2 and supply a DC voltage from a battery and series resistor, or, if you prefer, check the transistor.

Summary

While motorless remote control might seem complicated at first glance, the control circuits are actually rather simple, because only DC voltages are involved. Nearly every stage can be checked by application of a DC voltage to its input. Of course, current-limiting resistances should be used to prevent damaging a good component.

The controlled circuits are more **different** than difficult, but after the newness wears off, servicing becomes routine. The circuits controlling volume and color are essentially the same; both are basically gain-controlled systems. The tint-control circuitry consists of two simple gain-controlled amplifiers functioning together.

And, while troubleshooting these circuits initially can pose some new problems, at least we are done with an old one—finding all those little gears and cams that fell on the floor while we were changing a motor. ▲

Driving without safety belts is really asking for it.



Advertising contributed for the public good



IF YOU ARE A TV REPAIR MAN YOU NEED TV TECH AID!

TV TECH AID is the best trouble shooting guide available today. It takes all the guesswork out of TV repair and is designed to help you solve your problems quickly and economically.

Each month you receive updated information on up to 40 different troubleshooting cases. This important information is supplied to us by technicians, field reps and all the leading TV manufacturers. You will find every symptom pictured with a clearly marked schematic of the particular faulty stage. The faulty components and corrections will also be listed to aid in repair. You go right to the source of the trouble without guesswork. In addition you get valuable information on current models as well as older models along with circuit changes and modifications as they occur.

TV TECH AID is the best investment you can make in your own business. The cost to you is only \$7.95 for a full years subscription.

Send for it now . . . You'll be glad you did!

TV TECH AID

P.O. BOX 603
KINGS PARK, L. I.
NEW YORK 11754

ENCLOSED IS A CHECK OR M.O. FOR \$7.95. PLEASE SEND 12 ISSUES OF TV TECH AID

TO:

NAME

ADDRESS

STATE ZIP

Circle 25 on literature card

productreport

for further information on any of the following items, circle the associated number on the reader service card.

Color Tuner Cleaner and Lubricant

RCA Deluxe Color Tuner Cleaner-Lubricant (stock No. SC100) is designed for use on all black-and-white and color tuners.

RCA states that the spray is specifically compounded to leave no



residue that will affect operation of high-performance tuners. The manufacturer also states that the compound will not cause drift, detuning or oscillation of the tuner.

Reportedly non-flammable, non-toxic and safe for plastics, the cleaner and lubricant is available in an 8-oz. spray can, priced at \$1.95.

Circle 60 on literature card

Telephone Dialer System

James Electronics has made available its new "Silent Signalman" telephone dialer, designed for homes, offices, factories and stores where full protection is required.

Model C-7518 is a two-channel system that can be used for police,



fire or other protection messages. Each channel, on command, will dial up to three separate telephone numbers, deliver a pre-recorded message and then reset for further input information.

It operates on 110- to 130-volt AC power and also has battery standby provisions. The Silent Signalman reportedly is easily installed in a telephone system and is contained in a 5-inch X 13½-inch X 7-inch steel case. The price is \$249.95.

Circle 61 on literature card

Swivel-Head Plier

The new Swivel-Head Plier, with interchangeable heads, is now available from the Electronic Tool Division of the C. H. Mitchell Co.

Made of drop-forged steel, the plier has four interchangeable heads, which can be set at any of eight locking positions at 45-degree points



Swivel-Head Plier

around a full 360-degree circle. The heads include a long-nosed head with serrations, a short duck-bill head with serrations and a retainer-ring head with 0.06-inch pins at the tip. The body of the plier, with no head attached, measures 6 inches in length.

The plier set, Model SHP, is priced at \$17.95, complete with vinyl case.

Circle 62 on literature card

Boxes for Parts Inventory

A new line of transparent plastic storage and utility boxes for small hardware and electronic components has been announced by EPD Industries, Inc.

These boxes can be stacked or used in bench-top racks for easy

access to small parts. The recessed lids are tight-fitting to keep stored parts dust-free.

Two sizes are available: The 4-inch X 4-inch X 2½-inch boxes sell for \$.45 each in quantities of less than 100 and for \$.25 each in



quantities of 2500 or more. The 8-inch X 4-inch X 2½-inch boxes range in price from \$.55 each for quantities of less than 50 to \$.36 for 1250 or more.

Circle 63 on literature card

Easy-Read Fuses

An easily readable fuse is announced by Workman Electronic Products, Inc.

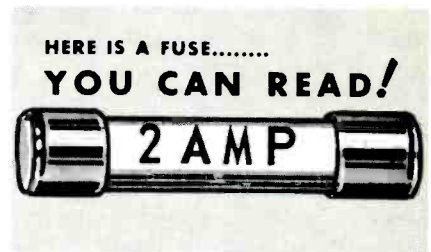

The easy-read fuses are available in values of ½ amp, 1½ amp, 2 amp, 3½ amp and 5 amp.

The list price is \$.25 each.

Circle 64 on literature card

Bench Illumination System

The OCVI Instrument Division of the Ednalite Corp. has introduced the StrutLite System. The system consists of three illumination instruments designed to provide greatly improved, safe and



dependable visibility to the user and for continuous work applications.

These three illumination instruments, consisting of a spotlight

Shortstop.

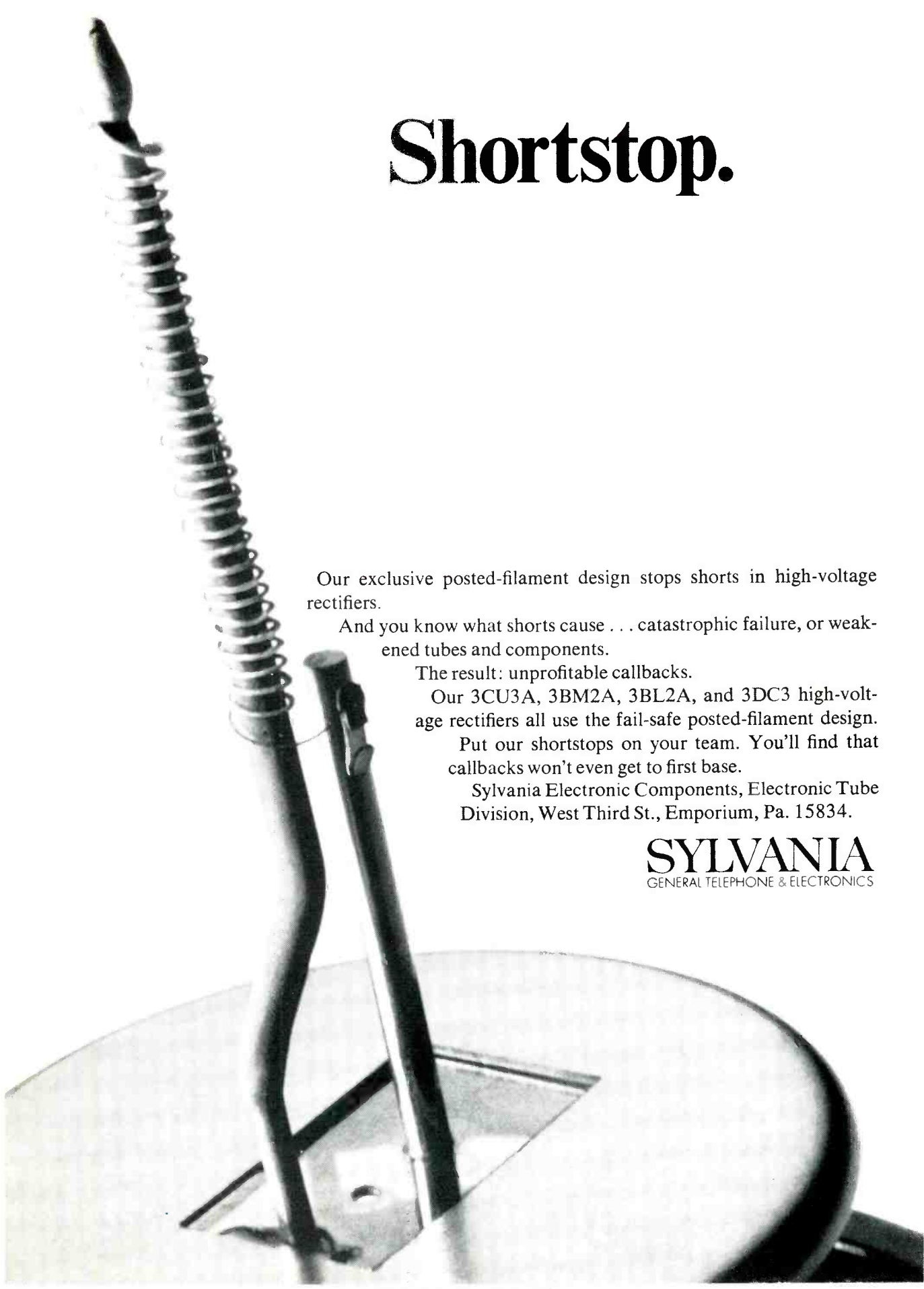

Our exclusive posted-filament design stops shorts in high-voltage rectifiers.

And you know what shorts cause . . . catastrophic failure, or weakened tubes and components.

The result: unprofitable callbacks.

Our 3CU3A, 3BM2A, 3BL2A, and 3DC3 high-voltage rectifiers all use the fail-safe posted-filament design.

Put our shortstops on your team. You'll find that callbacks won't even get to first base.

Sylvania Electronic Components, Electronic Tube Division, West Third St., Emporium, Pa. 15834.

SYLVANIA
GENERAL TELEPHONE & ELECTRONICS

Circle 26 on literature card

THE BEST PERFORMING SPLITTERS AND MATCHING TRANSFORMERS

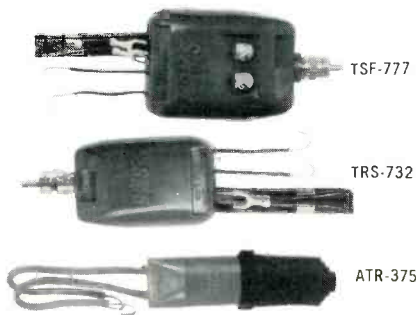

RMS has the most complete line of Splitters and Matching Transformers required for multiple-set home installations, master antenna systems, and closed circuit TV systems. All have unbeatable, dependable ratings. #SPF-555 3-Way UHF/VHF/FM Splitter. #SP-332 UHF/VHF Splitter. #TSF-777 UHF/VHF/FM Splitter and Matching Transformer. #TRS-732 Universal Matching Transformer and UHF/VHF Splitter. #TR-730 Matching Transformer. #ATR-375 Weather-Proof Antenna Side Matching Transformer. For complete specs and Profit picture—Write:

RMS ELECTRONICS, INC.

50 Antin Place, Bronx, N.Y. 10462
• Tel. (212) 892-6700

Circle 27 on literature card

(StrutSpot), a floodlight (StrutFlood) and a fluorescent light (StrutFluorescent) are mounted on a balanced strut system that reaches, stretches, folds, turns and swivels for all positioning on the work area. All use standard bulbs. The transformer and voltage combinations reportedly increase bulb life over ordinary high-intensity lamps. Also, the outer lamp housing stays at room temperature because of the new convection cooling housing.

StrutSpot has a long, burnished nose extension, and is designed for intensive examination of small areas or objects. Its two-level light switch provides the user optional intensity. This instrument reportedly has a special lens system, and color filters are also available for specific chromatic illumination.

StrutFlood illuminates a larger work area. It also has a two-level light intensity switch to provide flood illumination.

StrutFluorescent employs two standard fluorescent bulbs that reportedly give the work area cold-light illumination. An OCVI Illum-

ination Intensifier is built into the housing to increase the concentrated light output from these standard bulbs by about 50 percent, according to the manufacturer. The standard bulbs are interchangeable with GE UV fluorescent lamps or the equivalent, to produce ultraviolet illumination for fluorescent or black-light requirements.

The StrutLite structure stretches approximately 15 to 17 inches, depending on the model, and will compact to about 6 inches. Each has a full 360-degree rotation and each is equipped with 3-wire heavy-duty line cord, including a 2-wire adapter with ground connection. StrutSpot provides a 2-inch diameter illumination at an 8-inch distance.

The StrutSpot lists for \$54.00, and the StrutSpot filter kit is priced at \$16.95. Both the StrutFluorescent, complete with intensifier, and the StrutFlood sell for \$48.00.

Circle 65 on literature card

Tuner Degreaser

A new, improved degreaser for cleaning and restoring greasy and/or dirty tuner contacts is now available from Chemtronics Inc.

The new tuner spray reportedly is warmer to reduce detuning recovery time and is more powerful in its cleaning action than any other tuner degreaser. WARM TUN-O-WASH uses a blend of Freon 12



plus special ingredients which make the new spray approximately 25 degrees (F) warmer than the original TUN-O-WASH. Therefore, contacts and components sprayed with the new degreaser dry more rapidly, do not frost up and are less likely to crack, according to the manufacturer.

The 24-oz. spray cans sell for \$3.25 each. ▲

Circle 66 on literature card

HOPPING ALL OVER TOWN FOR REPLACEMENT PARTS . . .

Just hop to

STANCOR...

for all your exact monochrome and color TV replacement needs.

Stancor Products offer a complete line of flybacks, yokes, vertical outputs, audio outputs, power width and linearity controls for all major manufacturers.

Stocked by over 1,000 Service Part Distributors. Back up stock—Chicago, Dallas, Los Angeles, Hackensack and Atlanta.

ESSEX INTERNATIONAL, INC.

ESSEX CONTROLS DIVISION • STANCOR PRODUCTS • 3501 W. ADDISON ST. • CHICAGO, ILL. 60618

Circle 28 on literature card

AS OF NOW, IF YOU CAN'T FIND TECHNICIANS, YOU HAVE NO ONE TO BLAME BUT YOURSELF.

If you're in a business that in any way involves science, you know all about the technician shortage.

But did you know that The Advertising Council, the National Industrial Conference Board, and the Department of Health, Education and Welfare have joined forces and launched a campaign to end the shortage?

The advertising started running last May. Already millions of young people have got the message.

With your help, we think we can reach even more.

There are two principal ingredients in this campaign. The first is a booklet

giving all the facts on technical careers, technical schools and financial aid.

The other ingredient is a poster, offering the booklet.

You can help by handing out the booklet—and seeing that the poster is displayed in high schools, churches, youth clubs, wherever young people hang out.

For samples of both booklet and poster, information on ordering quantity reprints, and information on getting your firm's imprint put on the booklet, fill out and mail this coupon. Do yourself a favor. Mail it today.



Advertising contributed for the public good.

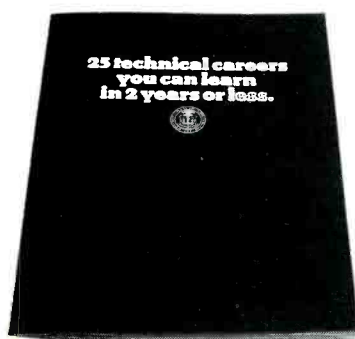

Booklet

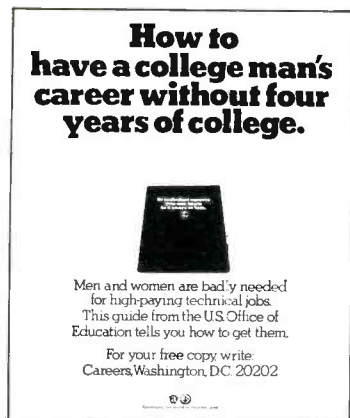

Poster

Technicians, P.O. Box 313
Radio City Station, New York, N. Y. 10019

Name _____

Firm _____

Business Address _____

City _____

State _____ Zip code _____

ADVERTISING

100. *Jerrold Electronics Corp.*—has made available a 10-page booklet, "Retail Advertising Guide for Dealers", which offers pointers on selection of advertising media, how to prepare ads and hints on creating ads with an underlying theme.
101. *Seton Name Plate Corp.*—has released a 64-page, 4-color Catalog 70-B, which illustrates their complete line of identification labels, advertising posters, truck signs, decals, name plates, warning tags and many other identification products, including technical data and price information.

ANTENNAS

102. *Cush Craft* — has issued their new Amateur Antenna Catalog, which includes photographs and specifications on more than 50 amateur antennas and accessories.
103. *Vikoa, Inc.* — is making available a 64-page, illustrated catalog covering their line of wire and cables and IDS/MATV equipment. Hardware, accessories, connectors and fittings and an index also are included.

AUDIO

104. *Daven, Div. of Thomas A. Edison Ind.*—a new means of building and expanding flexible intercommunication systems, Flexicom®, is described in Daven Bulletin FL-100.
105. *Robins Industries Corp.* — a 4-page, 2-color supplement to Robins regular 40-page catalog is now available. No. 7005 describes and illustrates 21 new audio-accessory products.
106. *The Turner Co.*—has published a 24-page, illustrated

catalog featuring specifications and prices on Turner's complete line of microphones; also included is a section on "how to choose a microphone".

CCTV

107. *GBC Closed Circuit TV Corp.* — has issued a condensed catalog covering their complete line of solid-state CCTV equipment.

COMPONENTS

108. *General Electric*—a 12-page, 4-color, illustrated "Picture Tube Guidebook", brochure No. ETRO-5372, provides a reference source for information about GE color picture tube replacements and tube interchangeability.*
109. *International Rectifier, Semiconductor Div.* — has issued two new catalogs: a 70-page, 4-color 1970-71 Cross Reference and Product Guide, listing IR's electronic dealer-service replacement products and including a complete cross reference guide divided into major device categories; and a 16-page, 2-color catalog, presenting solid-state components in a consumer format, available to IR's "Diamond Line" distributors.

SERVICE AIDS

110. *Chemtronics Inc.*—is releasing the 8-page 1970 edition of "Electronic Chemical Products Made Exclusively for the Industry", Catalog No. 7071, which covers their complete line of aerosol and bottled chemicals used to speed servicing.*

TECHNICAL PUBLICATIONS

111. *Howard W. Sams & Co., Inc.*—literature describes popular and informative

publications on radio and television servicing, communication, audio, hi-fi and industrial electronics, including their 1970 catalog of technical books on every phase of electronics.*

112. *Sylvania Electric Products Inc., Sylvania Electronic Components Div.*—has published the 14th edition of its technical manual, which includes mechanical and electrical ratings for receiving tubes, television picture tubes and solid-state devices. The price of this manual is \$1.90.*
113. *TAB Books*—has released their 16-page, illustrated spring, 1970, catalog, describing over 125 current and forthcoming books.

TEST EQUIPMENT

114. *B & K Mfg. Div., Dynascan Corp.*—is making available an illustrated, 24-page, 2-color Catalog BK-71, featuring B & K test equipment, with charts, patterns and full descriptive details and specifications included.
115. *Sencore, Inc.*—has issued its 12-page 1970 catalog, Form No. 517, which describes the company's complete line of test instruments and features 5 new instruments, with performance data and prices included.*

TOOLS

116. *General Electric* — has issued 2-page brochure No. GEA-8927, describing the features of GE's new soldering iron.*
117. *Techni-Tool, Inc.* — has released a catalog covering their new #4922 Aperture Cleaner, designed to clear holes and blocked eyelets.

*Check "Index to Advertisers" for additional information. ▲

ARE THERE TWO OF YOU?

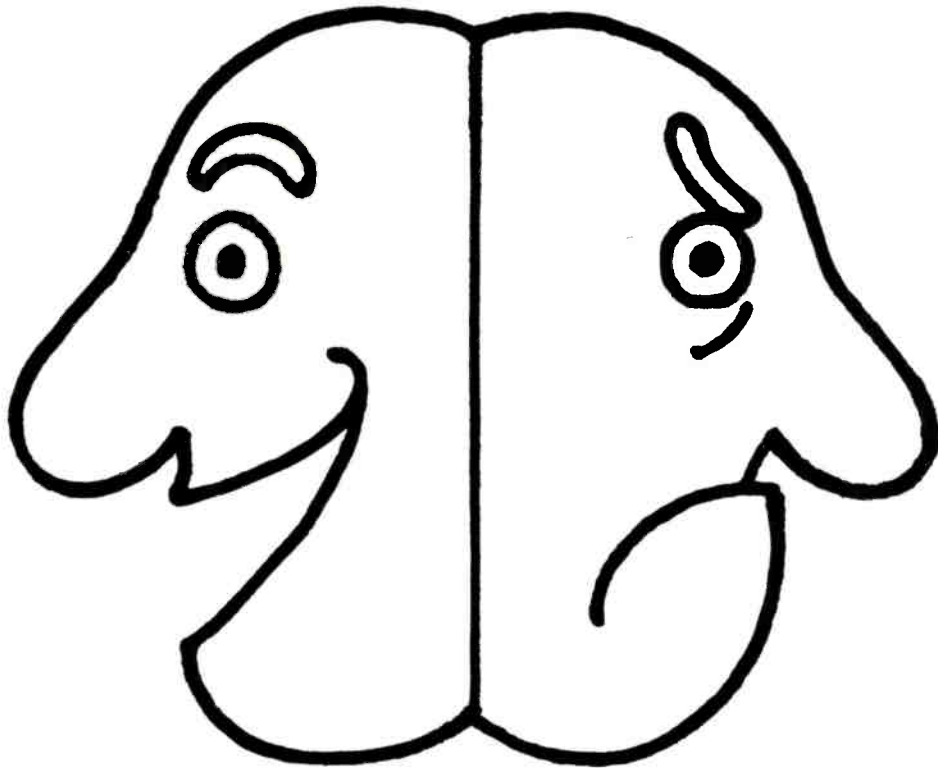

Love your neighbor

Business is business.

**Get while the getting
is good.**

It's dog eat dog.

**If I don't, somebody
else will.**

Why do so many of us think and act one way on weekends and another way when we go back to work on Monday? It's one world, you know. And it can become a better one only when a little bit of your better side starts rubbing off on the rest of the week.



Advertising contributed for the public good

advertisers' index



**WHAT MORE
CAN WE SAY?**

FROM **TECH
SPRAY**

Makers of famous BLUE SHOWER,
BLUE FROST and 33 other better
chemical tools for technicians.

P. O. Box 949 • Amarillo, Texas
Canada: Wm. Cohen, Montreal
Export: Empire Exporters, N.Y.C.

Circle 29 on literature card

American Telephone & Telegraph Co.	21
Bussmann Mfg. Division	8-9
C. R. T. Equipment Co., Inc.	25
Chemtronics, Inc.	39
Essex International Inc.	60
General Electric Co.	47, 50
Heath Company	19
Jan Crystals	31
E. F. Johnson Co.	51
Leader Instruments Corp.	37
Littelfuse, Inc.	BC
Precision Tuner Service	43
RCA Parts & Accessories	23
RCA Electronic Components ..	IBC
RMS Electronics Inc.	60
Raytheon Company	6
Howard W. Sams & Co., Inc.	35
Sencore, Inc.	13, IFC
Sprague Products Company	3
Sylvania Electric Products Inc.	1, 59
TV Tech Aid	57
Tech Spray	64
Tuner Service Corp.	5
Workman Electronic Products, Inc.	31
Xcelite, Inc.	24
Zenith Radio Corporation	29

Are you going to sit on the sidelines all your life?

What are you doing about what's wrong with our community? You. Not the fellow next to you. You.

Don't kid yourself. You know what the problems are. You read the papers. You listen to the gossip. Now get off the sidelines and into the game.

One way is to spend some time with one of our United Way agencies. Learn something of the new methods being used, the new programs under way. And the new money that's urgently needed.

That's the catch. For if you do let yourself become really informed, it'll cost you. You'll pledge more to the United Way than you've ever done before. You'll give your Fair Share.

If you don't do it, it won't get done.

 advertising contributed for the public good

10 million reasons why it pays to promote matrix, the brightest, sharpest color picture tube in RCA history!

Reasons 1 to 10,000,000. Large-screen MATRIX can upgrade the performance of at least 10 million color TV sets now in use. The RCA 25BCP22 is a direct replacement for the 25XP22, 25AP22A, 25BGP22, 25BAP22 (Chromacolor), and 20 other industry types! Giant-screen sales potential for the RCA MATRIX—practically unlimited!

More RCA Color Picture Tubes are stocked and

sold by distributors than any other color picture tubes in the industry. So, MATRIX is more readily available to you no matter where you are, to give your customers faster service and ring up more profitable sales.

MATRIX is the brightest and sharpest color picture tube in RCA history!

Here's why:



The RCA jet-black matrix®

It soaks up room-light normally reflected back at the viewer from the face of the tube. Result: brighter pictures because now there's no need to "filter out" brightness to maintain contrast under strong room-light conditions.

The RCA MATRIX phosphor-dot process*

First, we developed brilliant new phosphors and a unique screening process incorporating a jet-black matrix. Then we deposited the 1,200,000 red, green, and blue high-intensity phosphor dots precisely within the black matrix. Result: brightness doubled with dramatic improvement in contrast and clarity.

The RCA MATRIX picture**

Spectacular! In operation, a new, unique high-resolution gun "shoots" the phosphors with more energy than any other gun previously available. Result: black matrix — phosphors + high-resolution gun = maximum sharpness over the entire brightness range, truer colors under all viewing conditions.



New 4-color consumer flyer on MATRIX is available from your RCA Distributor.
RCA | Electronic Components | Harrison, N. J. 07029

*Magnified drawing **Simulated



EXACT

MAJOR-BRAND RF CHOKE & COIL REPLACEMENTS

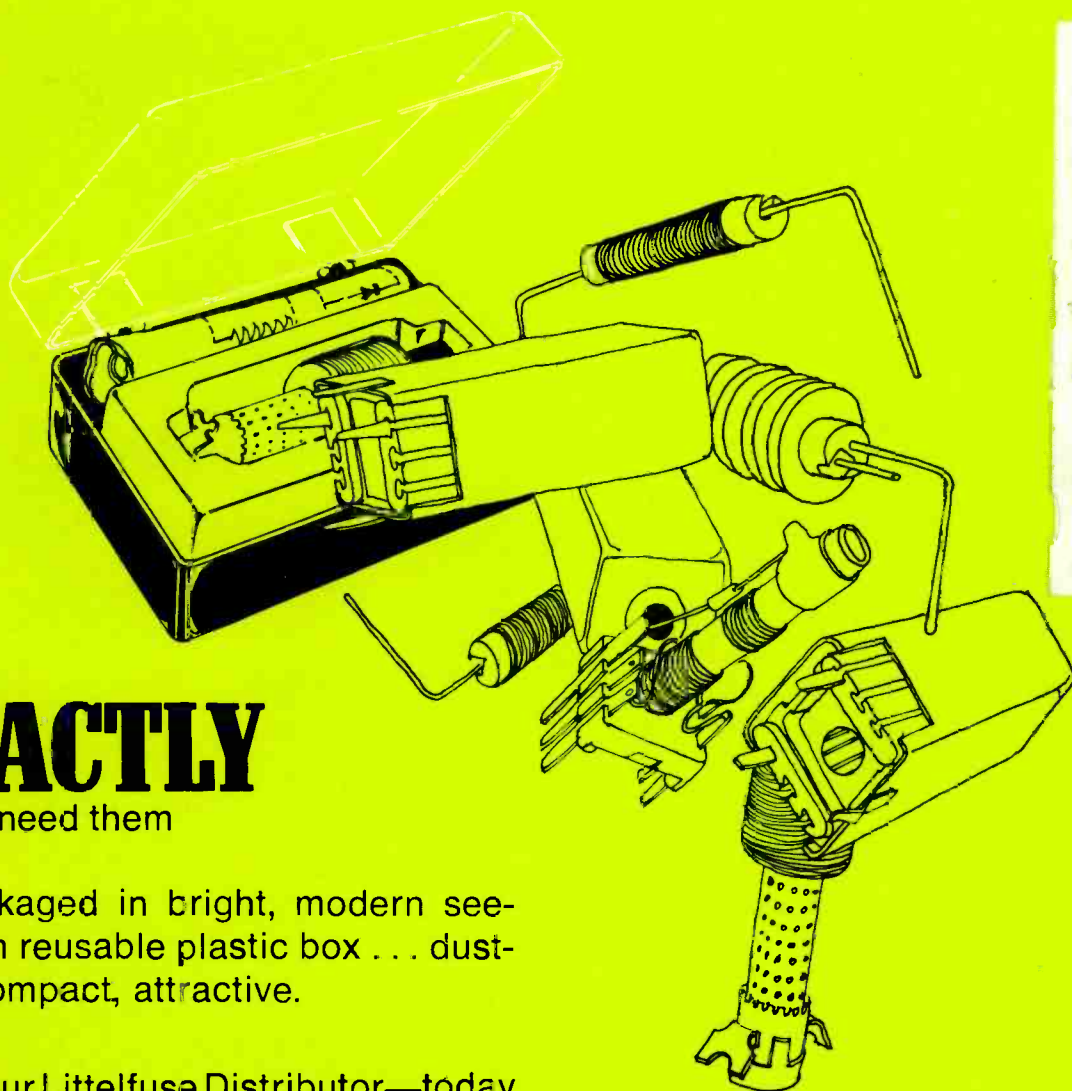

EXACTLY

as you need them

... Packaged in bright, modern see-through reusable plastic box ... dust-free, compact, attractive.

from your Littelfuse Distributor—today

ES11-469 N 1A 1071 4
P. J. BREIDEL
BREIDELS RADIO-TV SVC
1316 S 13TH ST
LA CROSSE WIS 54601

LITTELFUSE

800 E. NORTHWEST HIGHWAY DES PLAINES, ILLINOIS 60016 312/824-1188

Circle 2 on literature card